

A Study of the Beaver Creek Watershed:  
historical sedimentation, contemporary ecology  
and hydrology with predictive modeling

André Zimmermann  
Cariad McIlhagga  
Cherie Jarock  
Ondrea Rogers

submitted to:  
Kathryn Harrison  
George Spiegelman

For Environmental Sciences  
University of British Columbia  
April 1999

## **Executive Summary**

The Beaver Creek watershed is located within Stanley Park, Vancouver, B.C. The watershed has been and continues to be subject to human-induced stresses and influences. Two of these major influences are the roads and trails running through the park, and the GVRD water which currently supplies the majority of the water entering the basin.

Concern has grown over the past 15 years over the build-up of sediment and the overall shrinking of Beaver Lake, a 3.8ha body of fresh water in the basin. An introduced species of water lily (*Nymphaea odorata*) has been thought to be causing rapid sedimentation of organic material. The Beaver Lake Environmental Enhancement Project, a community group formed out of concern for the watershed, is faced with the task of evaluating management options for the basin.

The research group evaluated several properties of the basin, including lake-bed sediments, hydrology and ecology. A significant inorganic sediment source was found, with inorganic material making up 60% of some samples. This indicates that inorganic material contributes significantly to sedimentation occurring within the lake. Sedimentation rates were determined through analysis of sediment cores for metals and subsequent correlation to radiometrically-dated results from Burnaby Lake. Specifically, zinc was used to estimate a sedimentation rate which is much slower than previous estimates.

A predictive hydrological computer model was also constructed. This model was recession-based and designed to take into account the effects of evaporation on stream discharge. The model was used to evaluate the impact of the city water supply on the system. Lake and creek water levels dropped drastically with the elimination of the city water, but winter precipitation amounts were sufficient to keep a substantial amount of water flowing through the lake and creek. A literature review of the basin's ecology was compiled to evaluate interactions occurring between the various components of the system.

Research results were integrated together with a set of values to form a set of recommendations for the management of the watershed.

## Table of Contents

1. Introduction.....	1
2. Ecosystem-management: theory and application.....	4
3. History of the Beaver Creek watershed.....	7
3.1. 1850 - 1996 .....	7
3.2. The BLEEP years.....	9
4. Site description.....	12
4.1. Geological history .....	12
4.2. Soils .....	12
4.3. Hydrology .....	14
4.4. Ecology .....	14
5. Investigation of the hydrology of the watershed.....	17
5.1. Hydrological description of the Beaver Creek watershed.....	17
5.1.1. Beaver Creek.....	17
5.1.1.1. The importance of gravel in terms of fish habitat.....	18
5.1.1.2. The importance of stream-side vegetation and LWD for fish habitat.....	20
5.1.1.3. The armoring of the Beaver Creek channel .....	20
5.1.2. Tributary streams of Beaver Lake.....	21
5.1.3. Induced channelization of the watershed .....	22
5.2. The forest soil .....	23
5.2.1. Artificial wetlands.....	23
5.3. The water level of Beaver Lake .....	24
5.4. The hydrological model .....	25
5.4.1. The conceptual idea .....	25
5.4.2. Comparison to other hydrological models.....	25
5.4.3. Basin characteristics.....	26
5.4.3.1. Groundwater flow in the Beaver Lake basin.....	27
5.4.4. A water balance approach.....	28
5.4.5. Precipitation .....	30
5.4.6. Evaporation.....	32
5.4.7. Stream Runoff.....	36
5.4.8. Inputs into the lake.....	41
5.4.9. The modeling of lake outflow.....	41
5.4.10. Starting parameters for the model.....	45
5.4.11. Results of the model.....	47
5.4.12. Discussion of the model.....	51
6. Analysis of the lake Sediments .....	54
6.1. Field visit .....	54
6.1.1. Field methods and materials .....	54
6.1.2. Field description of cores.....	58
6.2. Lab methods and results.....	58
6.2.1. Visual description of cores.....	59
6.2.2. Mazama ash .....	67
6.2.3. Bulk density .....	68
6.2.4. Total nitrogen.....	69

6.2.5. Total carbon .....	69
6.2.6. Percent organic.....	69
6.2.7. Carbon to nitrogen ratios .....	70
6.2.8. Mineral size fraction .....	72
6.2.9. Metals.....	74
6.2.9.1. Sources of heavy metals.....	75
6.2.9.2. Analysis for metals.....	76
6.2.9.3. Metal profiles .....	76
6.2.9.4. Correlation tables .....	80
6.3. Discussion of sediments.....	86
6.3.1. Chemical availability .....	87
6.3.2. Sedimentation rates in Beaver Lake.....	87
6.3.3. How long will it take to fill in the lake? .....	90
6.3.4. Sources of sediment .....	91
7. Ecology of Beaver Lake.....	93
7.1. Water quality.....	93
7.1.1. Dissolved oxygen.....	93
7.1.1.1. Factors which affect dissolved oxygen .....	96
7.1.2. Temperature .....	96
7.1.3. Other factors.....	97
7.2. Anaerobic respiration.....	97
7.3. Macrophytes.....	97
8. The “natural” basin. ....	100
9. Integration of results: summary .....	102
9.1. Lake level and vegetation.....	102
9.2. Lake level and bog .....	102
9.3. Lower flows through Beaver Lake and fish.....	103
9.4. Lower flows in Beaver Creek and fish.....	103
9.5. Sedimentation rate and lake level .....	104
9.6. Aquatic vegetation and organic sedimentation .....	104
9.7. Sedimentation and decomposition rate .....	104
9.8. Catchment basin and inorganic sedimentation.....	105
9.9. Catchment basin and metal contaminants.....	105
10. Framework and values .....	106
11. Recommendations.....	108
11.1. Recommendation #1: Do not dredge the lake.....	108
11.1.1. Scientific evidence .....	108
11.1.2. Logistics .....	108
11.1.3. Values .....	109
11.2. Recommendation #2: Reduce the inorganic sedimentation rate.....	109
11.2.1. Scientific evidence .....	109
11.2.2. Logistics .....	109
11.2.3. Values .....	110
11.3. Recommendation #3: Develop an interpretive program relating to ecosystem processes within the Beaver Creek watershed. ....	110

11.3.1. Scientific evidence .....	111
11.3.2. Logistics .....	111
11.3.3. Values .....	111
11.4. Recommendation #4: Decrease city water supply .....	112
11.4.1. Scientific evidence .....	112
11.4.2. Logistics .....	113
11.4.3. Associated values .....	113
11.5. Replacement of the weir .....	113
11.5.1. Scientific evidence .....	114
11.5.2. Logistics .....	114
11.5.3. Values .....	115
12. Conclusions .....	116
13. Acknowledgments .....	117
14. List of References .....	118
15. Appendices .....	123
15.1. Appendix I -Culvert flow design .....	123
15.2. Appendix II plan view of weir .....	127
15.3. Appendix III inorganic grain size analysis .....	128
15.4. Appendix IV - metals and organic .....	130
15.5. Appendix V - recession data .....	131
15.6. Appendix VI metals, not normalized by carbon .....	132
15.7. Appendix VII -Moist and ground up core descriptions .....	136

## List of Figures

Figure 1-1 Stanley Park with the Beaver Creek watershed outlined (GVRD 1974).....	2
Figure 4-1 Map of the hydrology and creeks of the Beaver Creek watershed .....	13
Figure 5-1 Braided section of Beaver Creek.....	19
Figure 5-2 Water movement through the model.....	29
Figure 5-3 Composite soil profile and associated water storage areas. ....	31
Figure 5-4 Giles <i>et al.</i> (1985) data for $\alpha$ as a function of $\theta_e/E_{eq}$ .....	35
Figure 5-5 Stream flow recession data for the Beaver Creek watershed .....	38
Figure 5-6 Area - depth relation.....	42
Figure 5-7 Depth-volume relation.....	43
Figure 5-8 Main weir on Beaver Lake .....	43
Figure 5-9 End view of secondary culvert .....	45
Figure 5-10 The model's pre-simulation window.....	46
Figure 5-11 The "Set Parameters" window in the model. ....	47
Figure 5-12 Five-year run: no city water (Jan. 1, 1991 – Dec. 31, 1995). ....	48
Figure 5-13 One-year run: no city water (Jan. 1, 1993 – Dec. 31, 1993).....	49
Figure 5-14 One-year run: artificial water supply (Jan. 1, 1993 – Dec. 31, 1993) .....	50
Figure 5-15 One-year run: no evaporation (Jan. 1, 1993 – Dec. 31, 1993) .....	51
Figure 5-16 Ratio of 24-hour Evaporation to Incoming Solar Radiation .....	53
Figure 6-1 Taking a sample with the Hiller Corer .....	56
Figure 6-2 Map of Corer sites .....	57
Figure 6-3 schematic sediment profile of the lake .....	58
Figure 6-4 Bottom section of the AL4 core .....	60
Figure 6-5 Top section of the BL1 core .....	61
Figure 6-6 Middle section of the BL1 core .....	62
Figure 6-7 Bottom section of the BL1 core .....	63
Figure 6-8 Top section of the AL3 core.....	64
Figure 6-9 Bottom section of the AL3 core .....	65
Figure 6-10 Bulk density profiles for BL1 and AL4 core.....	68
Figure 6-11 Linear trend for percent carbon vs. percent organic .....	70
Figure 6-12 Nitrogen, carbon, organic, and C:N ratio profiles.....	72
Figure 6-13 BL1 cumulative percent finer than.....	73
Figure 6-14 AL4 and AH3 cumulative percent finer than .....	73
Figure 6-15 AL4 heavy metal profiles normalized for carbon.....	78
Figure 6-16 BL1 metal profiles normalized for carbon .....	80
Figure 7-1 Dissolved oxygen sample sites (Lashek <i>et al.</i> 1998).....	95
Figure 7-2 1984 Vegetation on Beaver Lake (Hatfield Consultants 1984).....	99
Figure 9-1 Interactions within the Beaver Creek watershed .....	102

### List of Tables

Table 5-1 Depth - surface area relation.....	42
Table 6-1 Core samples and field sample lengths.....	55
Table 6-2 Dry core descriptions for AL4 (top) and BL1 (bottom) .....	66
Table 6-3 Settling velocities based on stokes law for silt particles .....	74
Table 6-4 Correlation values for the AL4 core .....	82
Table 6-5 Correlation values for the BL1 core .....	83
Table 6-6 Correlation values for AL4 normalized for carbon.....	84
Table 6-7 Correlation values for the BL1 core normalized for carbon.....	85
Table 6-8 Sedimentation rates for Beaver Lake.....	89
Table 7-1 Dissolved oxygen values (Lashek <i>et al.</i> 1998) .....	95

## 1. Introduction

Water - our planet is covered in it and it sustains us. We drink it, we play in it; it governs our economy and our lifestyle. It has been woven into our cultures through stories, music and rituals. Issues surrounding water resources continue to spark debates across the globe: who has too little, who has too much, can it be bought, and does it respect the boundaries we have drawn around it? Increasingly, humans have begun to study the impact we have on our watershed systems. We have in many cases increased pollutant loadings, changed the hydrological regime through development, and altered the ecological state of these systems. We now face the challenge of existing within our watersheds while limiting our impacts on these systems.

Urban watersheds are a subject of much debate not only because they are often subject to huge human-induced stresses, but also because they exist under the eyes of a watchful public. This public may have various interests in the watershed and has the power to influence the state of the system as well as decisions made with regard to the watershed. Some view watershed management from a purely scientific point of view while others see it as a process of achieving social change (Heathcoate, 1998). In any case, humans play a large role in urban watershed systems.

The Beaver Creek watershed presents an interesting study of an urban watershed. It is a small watershed located within Stanley Park, Vancouver, British Columbia (see Figure 1-1). Within the watershed is Beaver Lake one of the very few freshwater lakes in the Vancouver area. As such, the lake and thus the entire watershed are used extensively by those who visit Stanley Park year round and find a quiet place away from the bustle of the city. The area presents the challenge of a watershed existing under extensive and in some cases intensive human impact.

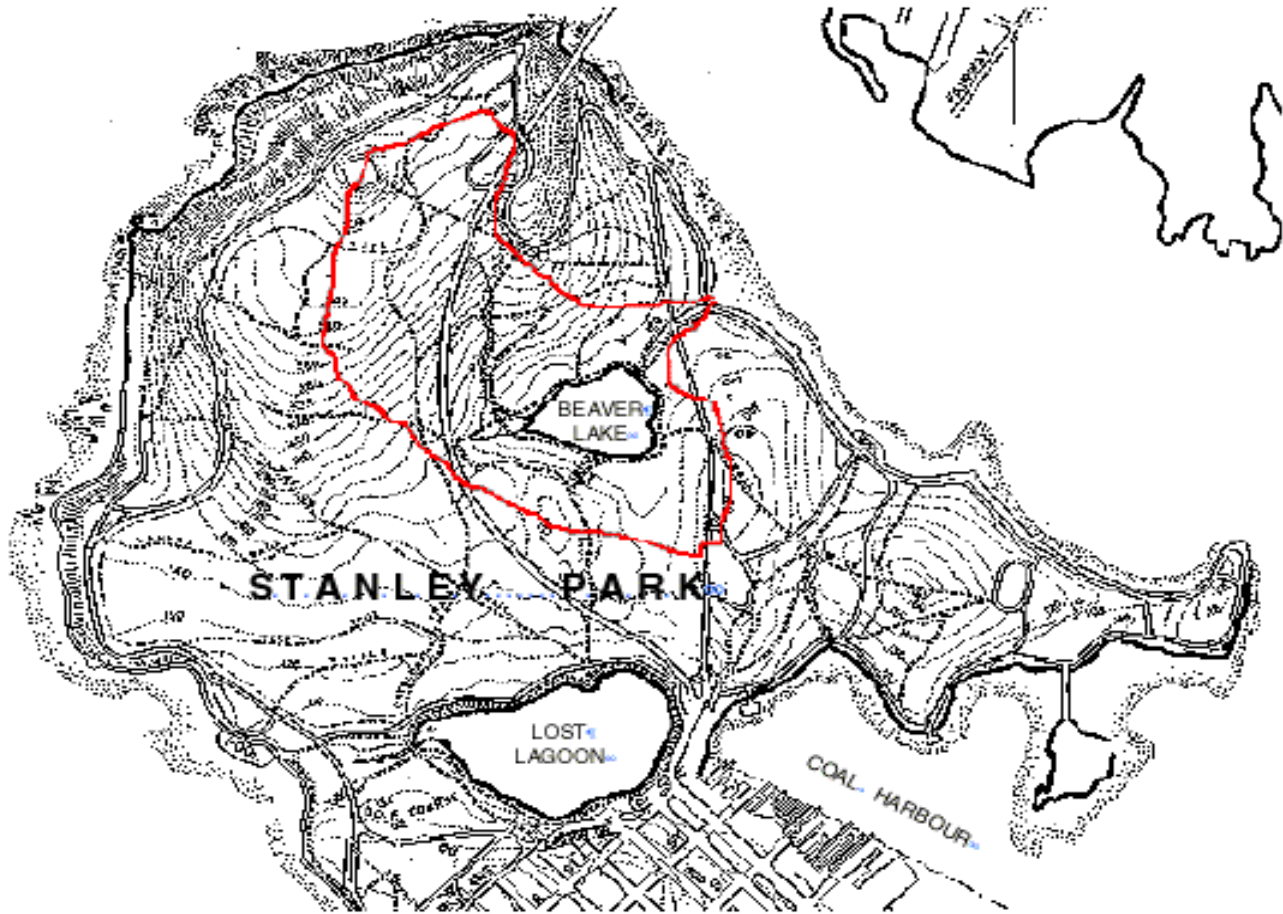

Figure 1-1 Stanley Park with the Beaver Creek watershed outlined (GVRD 1974)

The issues surrounding the Beaver Creek watershed are related to concerns over projected high sedimentation rates in Beaver Lake and can be summarized as follows: the disappearance of Beaver Lake itself due to infilling and therefore the loss of this resource for recreational and aesthetic purposes

- historic attachments to Beaver Lake as a lake ecosystem
- the desire to preserve this lake ecosystem as one of the few in Vancouver
- the desire to undo past human impacts on the lake
- loss of the bog ecosystem surrounding Beaver Lake due to infilling of the lake
- extinction of fish populations within the basin due to infilling of Beaver Lake
- the use of the Beaver Creek watershed as an educational resource
- preservation of the area as a place apart from the urban landscape

The Beaver Lake Environmental Enhancement Project (BLEEP) is a group of people concerned about the future of the Beaver Creek watershed. The group includes members of the Vancouver Parks Board, university professors and researchers, naturalists, members of the Vancouver Stream Society, members of the Stanley Park Ecological Society, and other concerned community members. The group is currently evaluating options for the future management of the watershed.

In an effort to understand the Beaver Creek watershed ecosystem, we performed an analysis on several components of the area. We studied the sediment record of Beaver Lake to determine sediment type, metal concentrations, and sedimentation rates. The hydrological regime of the basin was analyzed in an effort to evaluate the flow regime under various circumstances. A literature review of the biological component of the ecosystem was completed and used to approximate possible effects of changes in the watershed on the ecology in the area. Recognizing that these components do not exist independently of one another, the group analyzed the interactions between the three areas of study. Upon integration of the results of the study, a series of recommendations were proposed for the future management of the Beaver Creek watershed with the hope that this ecosystem will remain a dynamic system, an educational resource, and a respite from the noise of the city for years to come.

## **2. Ecosystem-management: theory and application**

When investigating the management problems and options for the Beaver Creek watershed, we found ourselves approaching the issues in a way concurrent with the theories of ecosystem management. This relatively new approach is being used more frequently in the field of watershed management. Faced with the degradation and destruction of many of our watersheds, most people realize and believe that a new way of doing things is crucial if we are to begin to manage these areas sustainably. Increasingly, planners, ecologists and the public view “ecosystem management” as the management tool of the future. Here, we present an overview of this approach as well as some of the questions surrounding this method of management.

While there is no consensus on a single definition for ecosystem management, there does appear to be agreement on some main themes behind the idea. R. Edward Grumbine has provided two very useful references with his essays entitled "What is Ecosystem Management? (1994)" and "Reflections on 'What is Ecosystem Management?' (1997)". These compile and summarise what various authors have written on the concept. The major themes deal both with physical/biological parameters as well as with the general way in which we think about managing systems.

First, “ecological integrity” is the most crucial concept to consider. Maintaining ecological integrity is commonly thought to mean maintaining viable populations of native species, representation of ecosystem types across their natural range of variation, maintenance of ecological processes, management of ecosystems over the long term, and accommodating human use within the above constraints (Grumbine, 1997). Some believe this idea needs to be broadened to include not only the range of natural variability, but also the landscape-scale pattern of occurrence of extreme conditions and recovery from stressed states (Frissell and Bayles, 1996). We must also recognize the influences that cause subtle but long-term, cumulative effects on the system. The second physical parameter is that of ecosystem boundaries. Boundaries of ecosystems must be defined according to natural features in the landscape, such as watersheds, rather than arbitrary

political boundaries. Third, ecosystem management places humans within the functioning ecosystem and their role within the system must therefore be defined.

In order to manage an area with these physical/ biological parameters in mind, there must be a shift in thinking. Ecosystem management requires multi-dimensional thinking, using various scales of evaluation at one time. While science clearly plays an important role in ecosystem management, ideological, philosophical, and political perspectives frequently override scientific facts. “Facts gain their meaning through the lens of theory and world views (C.E. Warren cited in Frissell and Bayles, 1996).”

The importance placed on each of these themes is usually where divisions occur. Stanley (1995), for example, sees two major groups involved in the debate. The one advocates a biocentric approach in which ecosystem integrity is considered paramount, with human uses of resources fitting in where the ecosystem can support it. The second group typically takes on a more anthropocentric view in which the interests of humans end up being paramount over ecological integrity. There are, however, a range of views in this argument. Some, such as Grumbine, believe that ecosystem integrity and human uses must be evenly balanced. He believes that this argument is “an artifact of narrow problem definition, lack of contextual thinking, and our propensity to separate ourselves from nature” and insists that ecological integrity is required to sustain human interests. Here is a “working definition” offered by Grumbine: “Ecosystem management integrates scientific knowledge of ecological relationships within a complex sociopolitical and values framework toward the general goal of protecting native ecosystem integrity over the long term.”

One interesting aspect of ecosystem management and management in general is the idea often put forward that it is necessary to undo past human impacts. Often, we seem to believe that we can undo past human impacts by further altering and manipulating the current system. Frissell and Bayles (1996) argue that such alterations should occur only when the goal is “...the reversal of artificial legacies to allow restoration of natural, self-sustaining ecosystem processes.” We attempt to follow these guidelines when making recommendations of the management of Beaver Lake

There is, and always has been, heated debate over how best to implement ecosystem management. It is inextricably tied to how the term is defined, but it seems that only through actually attempting to implement it can the definition be made clearer. This paradox led Brunner and Clark (1997) to recommend the adaptive approach to implementation over what they see as the two other main approaches: clearer goals and better scientific foundation. The adaptive approach to ecosystem management recommends using ecosystem-scale experiments to learn and gradually change our approach over time. Of course, others disagree. Many insist that there need to be fundamental changes in values and institutional structures before EM can even come close to being successfully implemented.

In a more general sense, some question our expectations and hoopla surrounding ecosystem management. They feel it is necessary to approach new management strategies with much greater humility. We are often in such a rush to improve, fix, and re-do past management mistakes, that we end up making new mistakes. We must recognize our past failures and realize that humans are not in control of the system, though we often believe we are. We cannot, though we may base our conclusions on the strongest scientific evidence, foresee all outcomes and plot out the path that nature will take. Instead of looking forward to predict the outcomes of management options, we choose to focus on investigating the history of the watershed as much as possible in order to determine the basic ecosystem processes. We feel that the conservation of these processes is the top priority since they will let the system evolve as “naturally” as possible.

### **3. History of the Beaver Creek watershed**

#### **3.1. 1850 - 1996**

The Beaver Creek watershed has been subject to various pressures imposed by humans, including logging, trail building, road building, and recreational use. However, considering its location in the middle of a metropolitan area, the watershed has undergone a relatively small amount of change. In 1850, the area now covered by Stanley Park was a mature coniferous coastal forest. Beginning in the 1860s and continuing through to the 1880s, most areas in the region were selectively logged (Beese 1989). The land between Beaver Lake and Lost Lagoon was the only area clearcut and burned (*Ibid.*). Following these alterations, the land was used as a military reserve and then converted into a park in 1888 (Steele 1988). Over the next 40 years, the Vancouver Board of Parks and Recreation attracted large numbers of people to the park for recreational purposes, including winter-time skating on Beaver Lake which attracted thousands (*Ibid.*). The trail around the perimeter of the lake opened up the area to visitors year-round in 1911 (Steele 1985). When cars first appeared in Vancouver, they were banned from Stanley Park for eight years. However, cars were later introduced to the park and by 1938 the Stanley Park causeway was completed, bisecting the park as well as the Beaver Creek watershed (Steele 1988).

At a similar time that cars began entering the park, various changes were occurring inside the watershed. A reservoir was installed in the late 1800's to supply Vancouver with water in case the waterline going to the North shore was damaged. It is believed that this reservoir was subsequently removed around 1910-1920 when the water mainline was brought over from the North Shore through a subsurface tunnel (Mike Boss, personal communication). This mainline now runs along Pipeline Road (*Ibid.*). To enhance recreational opportunity, the Parks Board built a fish hatchery on Prospect Creek (a tributary to Beaver Lake) in 1916 which provided a supply of salmon and trout into the lake (Steele 1985). Daily fish permits were sold allowing people to bring home as many fish as they could catch (Steele 1985). In order to maintain cool enough temperatures and

high enough oxygen levels in the lake to support fish, the Parks Board decided to input a steady stream of city water into the lake. This practice has continued to date. Because the lake was infilling naturally and was at a depth of only 1.2 meters in 1911 (Steele 1985), the Parks Board made two attempts to slow this process down. In 1918, all dead trees and edge debris were removed, then in 1929, the lake bottom was dredged (Stanley Park Task Force 1992). Water lilies were introduced in 1936 to commemorate the city of Vancouver's 50th anniversary (Schaefer and Chen 1988). Since this time the lilies have spread throughout the lake and nearly cover the entire lake surface in the summer. Other changes which have directly affected the lake are the building of the Beaver Lake trail and the concrete weir at the lake's outflow into Beaver Creek. Both of which were probably build in 1911. With the accumulation of all of these impacts on the lake, it is now difficult to determine what its natural condition was.

Although a management plan for Beaver Creek watershed has yet to be developed, a few plans have been developed for Stanley Park as a whole. Between the 1930s and 1980, there was a 25 per cent reduction in total forested land due to plans which called for the removal of old, dead and diseased trees, as well as plans for increased recreation (Beese 1989). In the 1940s a planting program was implemented to fill in logged areas with Douglas fir trees (Ibid.). An attempt to devise a comprehensive forest management plan for Stanley Park was made in 1980. However, due to budget limits, the plan was never fully implemented. A second attempt was made in 1984 by William Beese, a MacMillan Bloedel employee. The goal of this plan was to return the forest in Stanley Park as close as possible to the native coastal forest (Ibid.). The implementation of this 10-year plan began in 1989 with the removal of various deciduous trees and bushes in certain areas of the park. For example, 50 per cent of the alder trees in the region south of Beaver Lake were removed and conifers were planted, leaving a five meter buffer zone along the trail (Beese 1989b). However, park users reacted negatively to the cutting of trees and the implementation of the plan was stopped in 1991 (Stanley Park Task Force 1992).

Following this negative public reaction, the Parks Board decided to implement the Stanley Park Task Force to identify the community's values and priorities concerning

Stanley Park for long-term planning purposes (Ibid.). As a part of the report, a small section was dedicated to the management of Beaver Lake, however there was no public input gathered about this matter. The report outlined three potential directions for the plan. First, the lake could be left to natural succession into a meadow. Second, Beaver Lake could be preserved through dredging and removal of water lilies with machinery. Or, third, the lake could be preserved by enclosing the region for two years and introducing two moose. These moose could eat up the water lilies and, through swim patterns, naturally dredge the lake. The third option was the one preferred by the Task Force due to its low cost, possibilities as an interpretive resource, and its natural solution. Earlier, in 1984, Hatfield Consultants had prepared a Beaver Lake-Creek Enhancement Study in which dredging the lake was the recommended action to enhance the interpretive value of the watershed (Hatfield 1984). The future of the watershed has yet to be determined, however, a community group has formed with the intention of finding an appropriate management plan.

### **3.2. *The BLEEP years***

In 1996, a new body was formed called the Beaver Lake Environmental Enhancement Project (BLEEP). Although Parks Board staff undertook the lead role as facilitators of the new group. BLEEP, is a collaborative effort, and includes various community members. Since Beaver Lake is part of the Parks Board region, all recommendations and plans developed by BLEEP must be approved by the Parks Board before any action is taken.

Initially BLEEP was created for the purpose of reversing the human impact and restoring Beaver Lake to a condition similar to what it was. Mike Macintosh, the Stanley Park Wildlife Manager and one of the original facilitators of BLEEP, stated clearly his feelings about the future direction of Beaver Lake. "All ponds eventually fill in and revert to forest. But the lilies have accelerated that, and what we'd like to do is reverse the process, and get back to the point where we'd have a run of salmon into the lake again." (McMartin).

Since this original purpose, however, BLEEP has defined its mission and goals in a much broader context. BLEEP's focus has broadened beyond restoration of the lake to include interpretive programs. This is evident in the mission statement prepared:

- To create a primary wetlands interpretive area at Beaver Lake, supporting a vibrant diversity of naturally occurring species.
- To maximize the interpretive quality of the Beaver Lake aquatic and terrestrial environment while ensuring the protection of natural systems.

BLEEP (1996) also prepared five goals which allow them to accomplish this mission. The five goals are presented here with a brief discussion of how the group plans to attain each of those goals.

Goal #1 - To advocate the protection and conservation of Beaver Lake.

BLEEP has made a commitment to affirming a management and interpretive plan for the Beaver Lake area in order to attain this goal. Furthermore, they are initiating biological studies, and establishing a fund to pay for changes required resulting from the studies.

Goal #2 - To work cooperatively with other agencies and groups to achieve our mission. Partnerships have been developed on the foundation of consensus-based decision-making. Encouragement of interested parties to participate is ongoing. The Parks Board staff will act as project facilitators.

Goal #3 - To maintain and/or increase the present diversity of native species.

Studies, plans and actions will focus on enhancing existing habitat and developing new habitat to increase biological opportunity. The main method of developing new habitat will be through partial dredging of the lake. Furthermore, defined standards for monitoring and analyzing the environmental will be developed.

Goal #4 - To encourage responsible community based Stewardship of Beaver Lake.

The main ways this goal will be achieved are through: public relations, development of funding partnerships, and encouragement of studies from all levels of expertise. There will be an emphasis on direct action from any community group to enhance Stewardship.

Goal #5 - To develop a comprehensive interpretive program for Beaver Lake.

This goal will be met through a variety of possible measures, including brochures for a self-guided tour series, unobtrusive signage, special events and multidisciplinary

activities. Also, an awareness program will be developed about the negative impacts of introduced species.

Since BLEEP is a voluntary community group, it is limited in resources such as funding and time in accomplishing these all-encompassing goals. Over the past two years since the group has formed, the following has been accomplished by/through the society: placement of colonial bat houses, screech owl enhancement, squirrel demographic study, water quality study, bathymetric analysis, revitalization of Beaver Creek, bog study, and various studies involving human impacts on the lake through Capilano College. One of their major accomplishments was the organization of the Beaver Lake festival, which took place in June of 1997

## **4. Site description**

The Beaver Creek watershed has an area of approximately 112Ha (Coastal River Environmental Services 1995) and is mostly coniferous forest. The Beaver Creek watershed can be defined as the area from which precipitation is collected to eventually flow out the mouth of Beaver Creek. For our purposes, the most notable features of this watershed are Beaver Lake and its associated streams, Prospect and Beaver Creek. As can be seen in Figure 4-1, Prospect Creek flows southeast from Prospect Point to Beaver Lake, and Beaver Creek flows northeast into the First Narrows. The watershed has a maximum elevation of 70 meters (230 ft) and faces north. The geological history, soils, hydrology and ecology of the basin are all important features of this site.

### **4.1. Geological history**

Ten thousand years ago the last of the continental ice sheets retreated from the area that is now Stanley Park, leaving behind the land surface which now forms the Beaver Creek watershed. Features such as the Beaver Lake basin were left on the newly formed surface by these glaciers. Due to the immense weight of the glaciers, the Stanley Park area was underwater following the end of the ice age. Subsequent isostatic rebound has lifted the park up out of the ocean (Schaefer and Chen 1988).

### **4.2. Soils**

As a result of glaciation, much of the watershed was left with a blanket of glacial till which is now hidden beneath the soils and dense vegetation of the coastal forest. A small portion of this till is visible in the cut banks of Beaver Creek. The creek is incised into the glacial till about 3m in the lower reaches. During the time the watershed was underwater, a glaciomarine drift was deposited on top of the glacial till. As a result, the bottom of Beaver Lake is lined with these deposits, which act as a seal for the lake basin. The glaciomarine drift and the glacial till are the primary parent materials for the Ferric and Humic Podzol soils seen in the watershed today (Talisman 1995a). These soils help

determine the hydrological properties of the watershed as well as the vegetation characteristics.

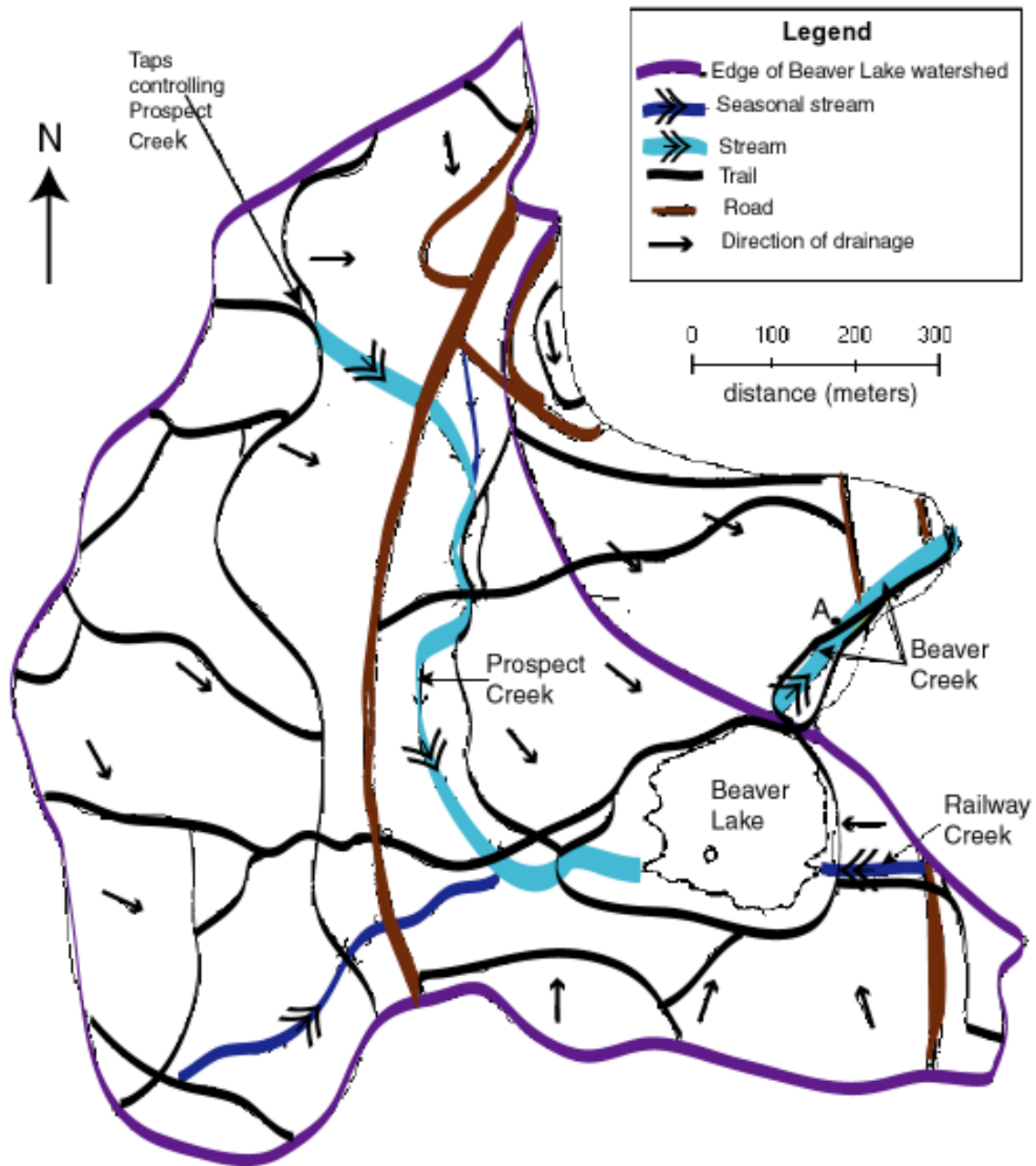

**Figure 4-1 Map of the hydrology and creeks of the Beaver Lake watershed<sup>1</sup>**

<sup>1</sup> (modified from Talisman 1995a, figure 3)

### **4.3. Hydrology**

The hydrology of The Beaver Creek watershed is largely influenced by the weather patterns of Vancouver. The winters are typically wet with infrequent snowfall. The summers are much drier with only a few large rain events in July and August. The natural water source for the Beaver Creek system is subsurface seepage from the watershed terrain, and the inflow of Prospect Creek. Although the channel has been lengthened by park managers, Prospect Creek appears to be the only developed natural channel which feeds Beaver Lake. The extension of Prospect Creek is a result of water flow from the reservoir which used to be located at Prospect Point.

The current water flow has been altered from its historical patterns in a number of other ways as well. A brief description is given here, for a more detailed description see Section 4. The flow of Prospect creek is augmented by the city water supply which pours approximately  $0.184\text{m}^3/\text{s}$  (Wu *et al.* 1999) of chlorinated water into what has become the headwaters of Prospect Creek (Talisman 1995a). Seepage from a fire-hydrant, near the aforementioned pipe also supplies artificial water to the system. On the same side of the causeway, but a bit farther south, a drinking fountain supplies additional water to the soil. This water is eventually incorporated into subsurface flow. The last notable anthropogenic water source is Railway creek which has developed from water flowing out of a two inch pipe into a culvert which runs under Pipeline Road. See Figure 4-1 for the location of these creeks..

### **4.4. Ecology**

The ecology of the Beaver Creek watershed incorporates complex and interrelated biological factors. These factors interact with each other, the hydrology and geology of the watershed, as well as the ecology of the surrounding park areas. Numerous plant and wildlife species occupy both the terrestrial and freshwater habitats of the watershed, despite the constant human disturbance which is a consequence of being an urban park.

The primary terrestrial habitats are the coniferous forests typical of the Drier Maritime Coastal Western Hemlock subzone (Nuszdorfer et al. 1985, cited in Talisman 1995b). The stands are dominated by western hemlock (*Tsuga heterophylla*), Douglas-fir (*Pseudotsuga menziesii*) and western red cedar (*Thuja plicata*). Western Hemlock is the

expected climax species, but in many areas disturbances have resulted in sub-climax communities dominated by Douglas-fir. One of these areas is in the southwestern portion of the watershed, which was logged and burned in the 1880s (Beese 1989). Other areas in the watershed have been selectively logged. As discussed in Robertson and Bekhuys (1995), these coniferous forests help provide habitat for such creatures as coyotes, raccoons, skunks, small mammals such as bats, squirrels and mice, as well as numerous forest birds.

Deciduous stands of bigleaf maple (*Acer macrophyllum*) and red alder (*Alnus rubra*) can also be found scattered throughout the watershed (Schaefer and Chen 1988). Robertson and Bekhuys (1995) show two fairly large deciduous habitat areas in the watershed. These deciduous stands provide habitat for many of the same species as in the coniferous stands, and they may also attract species which are specific to deciduous forests. The ring of red alder around Beaver Lake is another significant deciduous area. The presence of the alders may be due to (and a cause of) the decreasing size of Beaver Lake. The intermediate area between Beaver Lake and the alder stands is composed of species such as yellow iris, salal and skunk cabbage. This area likely provides the best amphibian habitat to be found in the park. There are also two small areas on the western edge of Beaver Lake which can be classified as bog systems (Coulson et al 1998).

The aquatic systems of Beaver Lake, Prospect Creek and Beaver Creek provide aquatic habitats in a mainly forested area. Beaver Lake is the only historically significant body of freshwater in Stanley Park. As of 1997, the surface area of Beaver Lake was 3.88 Ha with an average depth of 44cm (Stewart 1997). This area is much smaller than the 6.7 Ha recorded in 1938 (Steele 1985), although the maximum depth of 1.2m appears to have remained approximately the same. In the summer, up to 80% of the surface area is covered with aquatic vegetation (Hatfield 1984). These macrophytes, particularly the introduced water lilies have been viewed as the primary cause of the rather rapid decrease in the size of the lake. The lake supports many invertebrate species as well as a number of species of fish, including cutthroat trout, sticklebacks, lampreys and carp.

The creeks are also important fish habitat. Prospect Creek is the less disturbed of the two, with plenty of riparian vegetation. The fish living in this stream have the added

advantage of having access to the lake. Fish in Beaver Creek are prevented from entering the lake by the weir at the lake outflow. Both streams appear to support cutthroat populations which are thought to have been introduced by the hatchery and stocking operations which were carried out in the first half of the century (Steele 1985). Wild coho salmon are thought to have existed in the stream before the first world war, and may have been in the stream as late as the early 1980's (Steele 1985, Hatfield 1984). There is currently enhancement work being done to improve the fish habitat of these two streams, particularly in Beaver Creek.

## **5. Investigation of the hydrology of the watershed**

In this section we introduce the hydrological processes operating in the basin. These processes are of critical importance in regards to the supply of sediment, fish habitat and vegetation characteristics. We also describe a model designed for the watershed is described and the results from a number of runs are given. The model has proven to be useful in forecasting the consequences of removing the water artificially supplied to the system.

### ***5.1. Hydrological description of the Beaver Creek watershed***

The contemporary hydrological regime of the Beaver Creek watershed is influenced by past geomorphic process, the contemporary climate and vegetation patterns, as well as human activities in the basin . The Beaver Creek watershed drainage basin is 112 Ha in area (Coast River Environmental Services 1995, p.2-12) and is northeast facing.

There are four notable creeks in the basin which can be seen on Figure 4-1. Beaver Creek flows out of Beaver Lake into Burrard Inlet and is about 350 meters long. Prospect Creek, the longest stream in the basin, flows from near Prospect point into the West side of Beaver Lake. A seasonally active channel flowing from the west side of the basin joins Prospect creek just before the lake. Railway creek flows from a culvert near the miniature railway into Beaver Lake. Railway Creek and Prospect Creek are directly fed by water coming from the city's water supply.

#### **5.1.1. Beaver Creek**

The presence of fish in Beaver Creek has created a desire for high quality fish habitat in the creek. Fish habitat is controlled by a few important factors such as the availability of food, the temperature regime, the quality of the spawning gravel, and the availability of covered habitat during different flow conditions. These characteristics are largely influenced by the quality and quantity of gravel in the stream, and the supply of large woody debris (LWD) to the channel.

Beaver Creek in its “natural state” (i.e. without industrial human influence) would probably dry up during the summer months. Channels of a similar scale and larger are commonly seasonal and as such do not have surface flow during the summer. For example, segments of Carnation Creek on Vancouver Island dry up during the summer. Creeks of this type can support fish populations by having perennially deep pools. Small amounts of subsurface water flow through the gravel which makes up the steps and riffles separating the individual pools. In Beaver Creek there are few significant pools which historically may have held water through the year.

#### **5.1.1.1. The importance of gravel in terms of fish habitat.**

While the supply of gravel is necessary for productive fish populations an over-abundance of gravel can destroy fish habitat. New gravel is able to move down the channel and keep the spawning gravel clean. Excess supply can destroy fish habitat by causing the stream to aggrade (raise its bed).

At present there is undoubtedly an excess supply of sediment in Beaver Creek. The input of sediment from the trail along the creek and the weir at the lake outlet threatens to reduce the pool depths and the possibility of developing other pools along the channel. Pools are important to fish as places to hold out and wait for food, especially in high flow conditions. They are also important during low flow conditions in seasonal creeks because the pools may be the only places containing water.

In addition to causing the channel to become braided ( multiple channels) (Ashmore 1991, cited in Knighton 1998) the sediment may partially fill in pools as the stream does not have the capacity to move all of the gravel. During a January field visit a braided channel form Figure 5-1 was visible in the riffles located just downstream from the top culvert drop pool.



**Figure 5-1 Braided section of Beaver Creek**

Medium to coarse gravel can easily transport water through the subsurface and are ideal for spawning gravel. The sediment directs water away from the surface, and reduces the apparent flow. In creeks like Carnation Creek this process cools and aerates the water which flows into the pools holding fish. For Beaver Creek this process would operate, but would not be effective because the stream is only 300 meters long. There likely not sufficient time to cool the water coming out of Beaver Lake.

The current supply of sediment in Beaver Creek is not ideal for fish habitat. The volume of sediment entering the creek is larger than is needed for effective subsurface flow, and the sediment is too sandy to be highly effective. The road gravel on the trails has a high fraction of sand which fills in the interstices in the gravel. This armors the gravel and prevents water from supplying the eggs with oxygen rich water while removing toxins.(Mike Church, personal communication)

There is a fine line between too much sediment leading to the aggradation of the channel, and too little sediment and the degradation of the channel. Both of these negative impact fish habitat. Beaver Creek in its natural state would likely be sediment starved as the channel banks would be the only suppliers of sediment. Given the resistant

properties of the till, there would likely be limited bank erosion. The larger clasts which have fallen out of the till and are evident in the lower reaches of the stream will likely never move and will continue to supply important diversity to the channel.

#### **5.1.1.2. The importance of stream-side vegetation and LWD for fish habitat**

Stream side vegetation and large woody debris (LWD) are key features in high quality streams. As part of a stream enhancement project in Beaver Creek vegetation has been placed along the side of the channel and LWD has been placed in the channel. The vegetation helps reduce the supply of sediment from the channel banks and supplies cover to the channel. The LWD helps create pools for the fish.

In many river channels, stream side vegetation is also important as a supplier of LWD. As this channel is in a park with a developed forest canopy the planting of trees for future recruitment is not a concern. The characteristic height of the trees is much greater than the width of the creek valley and as such LWD may be limited in its effectiveness in the natural state (Nakamura and Swanson 1993). In the natural regime the over sized logs may eventually break after being suspended above the channel for a number of years. At this point portions of the logs may be recruited to the channel and contribute to channel complexity and fish habitat. The ability of LWD to become incorporated into the channel may be limited in the urban park setting as trail clearing may remove sources of in channel LWD.

#### **5.1.1.3. The armoring of the Beaver Creek channel**

As part of the recent stream enhancement work, rows of large cobbles have been installed along the stream edge in an attempt to confine the channel. The reason for this is unclear; the banks of the channel do not appear to be actively eroding in the areas where these stones were placed, and thus controlling the sediment supply by armoring the banks appears unnecessary. What is evident is that the stream, with a mean gradient of 1.4%<sup>2</sup>, is not powerful enough to move the cobbles which have been put in place. The stream is less likely to be able to meander freely and create a pool-riffle form using the

full width of the ravine. It is unclear whether or not there is sufficient room between the rows of cobbles for these features to develop. If the boulder chains along the banks are sufficiently resistant to erosion they will limit the ability of the channel to shift laterally (Hickin and Nanson 1984, cited in Knighton 1998). This will cause the channel to remain in a straighter form with a reduced chance of developing new pools apart from the drop pools at major steps along the channel. This critique of the armoring of the channel should be received in light of the fact that the author did not visit the creek prior to the initiation of the work and an important reason for the stones may relate to the pre-restoration state of the stream. Additionally, it should be noted that natural rearrangement of the cobbles is possible as they become undercut and reworked when local degradation of the channel occurs.

#### 5.1.2. Tributary streams of Beaver Lake

The streams that feed Beaver Lake follow the same sediment transport and stream organization principles as Beaver Creek. However, the flow regime in the current state is clearly altered from the natural state. Railway creek is entirely artificial; it flows as a result of road runoff during the winter months, and from piped in water during the summer months. It is very small, and can only be considered important in terms of a supply of cool water and possibly a few invertebrates. Prospect Creek clearly is natural in its origin. However, the current channel may be located in a new position as a result of the introduction of the causeway and the piped in water supply. Prospect Creek is incised one to two meters into the surrounding terrain for most of its length, and does not appear to be actively eroding its banks or to be overloaded with sediment. The lower reaches, which are fish bearing, are dominated by sand, and consequently do not contain much in the way of good spawning gravel. The small seasonal tributary to Prospect Creek has not been investigated; however, it can be considered important in terms of an invertebrate population and as a channelized source of water. In the tributary creek open channel flow forms at or just above the causeway during high rainfall events. This stream is by far the

---

<sup>2</sup> Measured from the 1:5000 "Surface Drainage" topographic map of Talisman (1995).

least disturbed, with natural LWD recruitment and without a human-induced supply of water.

### 5.1.3. Induced channelization of the watershed

In basins with areas less than about 50 km<sup>2</sup> the time that the water spends moving through the hill-slope is significantly more important in terms of outflow timing than the time spent moving through the stream channels (Knighton 1998). For the Beaver Creek watershed the time the water spends in the soil controls the characteristic response of the basin to precipitation events. The original drainage network was undoubtedly one with few channels and thus, the average drop of precipitation had to travel a fair distance to the available channels before being rushed out to sea. In the present day, a wide variety of human activities has forced new channels to form and has caused the average travel distance to the channels to be greatly reduced. This has likely shortened the response time of the watershed to rain events, both increasing the specific discharge of a given event and decreasing the duration of individual events. Under natural flow conditions there would be a decrease in the peak flood and an increase in the period of low flow in the basin.

The channelization has occurred primarily along the walking trails and along the roadways. The walking trails compact the underlying soil and lower the hydraulic conductivity, which interrupts down-slope drainage patterns and can cause the ponding of water on the uphill side of the trails. This process is known to form wetland areas on the uphill side of roadways and kill trees and other vegetation (Mike Church, personal communication). The local raising of the water table would be expected to occur along the upstream side of the causeway. However, engineering work to create deep (>1m) drainage ditches along the side of the road have ensured this does not happen. Rather these ditches act to drain the local soil and move water via channels down through the basin. An especially long drainage ditch exists at the north end of the causeway and is able to capture a significant amount of the subsurface flow which would ideally remain in the soil and slowly percolate downhill. This ditch drains across the causeway and, combined with direct rainfall runoff from the causeway, has formed a channel on the downhill side of the causeway. This meets up with Prospect creek shortly downstream.

The remaining two ditches which collect water from the upstream side of the causeway run through culverts under the road and plunge onto the soils on the downstream side of the basin. This water, combined with the direct runoff from the causeway appears to completely infiltrate into the soil and does not become channelized. Prospect creek also flows under the causeway and collects additional water from drainage ditches and the road surface. The soil filters this water in the same manner as artificial wetlands are designed to do.

## **5.2. *The forest soil***

The forest soil is the most important unit in controlling the hydrological response of the basin. All of the water which runs off in the basin runs off through the soil. The soil controls the quantity and rate of water flows. The soil floor is of unknown thickness, but is likely about half a meter thick. The soil in the basin ranges from poorly drained to well drained and are more fully described by Talisman (1995a).

### **5.2.1. Artificial wetlands**

Members of BLEEP are interested in knowing the potential benefits of using artificial wetlands to treat road runoff. Artificial wetlands are constructed to an attempt to make use of the filtering capacity of found in natural wetlands. In this location, the forest soils already act as a filter for the road runoff as long as the runoff is allowed to percolate through the soils. With only 2% of the water in the basin coming from the road, the treatment of water is a much smaller concern in this basin than in other urban basins (e.g. Burnaby Lake). However, with the extensive number of ditches, trails and roads throughout the park, the water is drained quickly out of the forest soil. This water and the water coming off the road should be put back into subsurface flow to increase the retention time of water in the basin. This is completed at two of the three culverts which cross the causeway. At the third culvert, the most northern, an artificial wetland could prove to be useful in re-introducing the water to the soil. The forest soil that already exists in the region can perform this task without any need for artificially constructed soils. . . N.D. Lea Consultants Ltd.(1998) have suggested on map R1-377-H355 that the culvert, which drains the ditch, should be sealed off and the drainage ditch should be

extended to Prospect Creek. This would not change current runoff patterns much, and would do nothing to increase the retention time of the basin.

How artificial wetlands would compare to the forested soils for increasing the retention time of water is unknown. We have not looked in detail at the characteristics of forested soils compared to wetlands. However, they likely have similar retention characteristics. The wetlands may perform modestly better as they will likely have no large pores (macropores). The natural soil floor is good at infiltrating water, and is the natural infiltrator which should exist in the Beaver Creek watershed.

### **5.3. *The water level of Beaver Lake***

The water level of Beaver Lake has been raised. We suspect the lake level was raised about 20-30 centimeters around 1911<sup>3</sup>. The weir was constructed with logs and then subsequently back-filled, creating the present day structure. There are two separate structures which pass water under the trails. The main culvert is a trapezoidal weir which contains the main flow of Beaver Creek. The second structure is a complicated set of culverts with a dam on the downstream side of the upper most culvert. In making the model these flow structures needed to be modeled. A plan view map is contained in the appendix and further details are contained in Section 5.4.9

With the addition of water, the lake level is artificially held at a winter high water level throughout the summer. This undoubtedly impacts the shoreline vegetation. By raising the lake level, the shoreline has been pushed back and the roots of some trees which grow in drier conditions have been drowned. This may be the reason for the debris removal in 1929 as along the lake edge there would be many dead trees (Steele 1985). In addition to this there may be changes in the vegetation around the lake as the vegetation no longer experiences a drying and wetting phase. This may preferentially select for specific species of plants, ones which would not normally inhabit lake margins with variable water levels. We do not expect the natural flow conditions to change the lake's water level much; however, it would be enough to dry up portions of the soil around the lake edges.

---

<sup>3</sup> This is a very rough guess, based on the weir being constructed when the trail was in 1911, we know a sluice gate was constructed at this time (Steele 1985).

## **5.4. The hydrological model**

### 5.4.1. The conceptual idea

A basic premise of the research group is that alteration of natural processes should be avoided when possible. The addition of city water, as discussed in section 3, is an example of one such problem. We are interested in knowing if the addition of city water from the North Shore Mountains can be stopped, or reduced, while keeping the crucial elements of the system intact. In order to evaluate how changes in the artificial water supply would affect the biological community it is necessary to first understand the underlying hydrological regime. As the hydrology of the basin is strongly altered by the artificial supply of water it is not possible to do field measurements to determine the normal course of hydrological processes. Thus it is necessary to model the flow regime if an understanding of the flow is to be attained. The purpose of this model is to determine the timing of the disappearance of channel flow, and the draw down of the lake during the summer months. The model has been designed to predict later summer stream flow recession.

### 5.4.2. Comparison to other hydrological models

Before going into the details of the model it is useful to describe the differences between this model and other models which predict stream flow. The biggest differences are that this model is designed to deal with seasonally dry streams, and it uses a stream flow recession approach for predicting runoff.

As Beaver Creek would be a seasonal stream, a model which is able to deal with seasonal flows is mandatory. In seasonal streams it is clear that evaporation must be important in controlling the runoff as at some point the evaporation, and runoff will be of the same order of magnitude. At this point the amount of evaporation, and runoff should have direct impacts on the stream flow. Only two of the papers reviewed on different hydrological models mention evaporation. Zecharias and Brutsaert (1988) are dealing with deep groundwater and found the evaporation to be small and set it equal to zero in the end. Post and Jakeman (1996) found evaporation to be important in their study, and account for it by subtracting it from rainfall by a method which is not clear. Their model

is empirical in design and has two “catchment factors” which would have to be estimated in our case. These “catchment factors” do not represent any particular measurable attribute of the basin and it is unclear how or if they could be estimated for a basin like Beaver Creek.

The use of a stream flow recession approach seems to be unique to our model. Post and Jakeman (1996) use a unit hydrograph approach while other models use an infinite slope (Zecharias and Brutsaert 1988) or Darcy’s law approach (Smakhtin *et al.* 1986). All of these approaches require the estimation of some values from field visits. The infinite slope equation and the Darcy’s Law approach require a hydraulic conductivity be measured or estimated for the basin as a whole, while our approach and the one based on a unit hydrograph require measuring the response of the basin as a whole. The latter two are likely better as the model is based on a value which is measured from the whole basin, rather than spot checks in the basin. We are able to use a recession flow model because we are assuming storm flow happens within a day. For larger basins this may not be the case and a recession flow model constructed as ours is would not be appropriate.

Part of the differences in the models results from the necessity for ours to be reasonable without calibration. Most of the models undergo some form of calibration, and are designed with this in mind. We could not expect to be able to calibrate our model because we did not have the time to construct a stream flow record, nor the ability to remove the artificial water supply from the lake.

Most hydrological models are made for basins much larger than ours and cannot ignore groundwater flow. We have a model which is designed to be useful for the Beaver Lake watershed specifically, and some of the factors we have ignored could not be ignored for other watersheds. The modeling of the lake as we have done is likely not unique, however, as the process is relatively simple we chose to construct the model ourselves.

#### 5.4.3. Basin characteristics

Figure 4-1 outlines the watershed boundary used in this study. The Beaver Lake watershed was calculated to have an area of 81Ha using a polar planimeter based on a

1:5000 map from Talisman (1995a, figure 3) as compared to the Beaver Creek watershed which covers 112Ha<sup>4</sup>. Beaver creek flows out of Beaver Lake and thus catches all the water flowing into the lake as well as additional water flowing directly into the creek. The lake is considered to have an area of 3.881Ha based on a water level equal to the bottom of the main weir draining the lake (Stewart 1997).

#### 5.4.3.1. Groundwater flow in the Beaver Lake basin

Under the forest soil exists a compact basal till. This forms a relatively impermeable “liner” for the basin and ensures most of the rainfall leaves the basin either through evapotranspiration or runs off through Beaver Creek. Hatfield Consultants (1985) estimated that about 10 percent of the water goes to groundwater recharge. This value seems large. To get an estimation of the runoff in the till, we can consider a cross section through which the water flows. If we look only at the Beaver Lake watershed (81 Ha in area), we calculate a cross section by considering the perimeter of the lake and the till depth. The perimeter of the lake is 400 meters in length, and the till is estimated to be on average two meters thick. This gives us a cross sectional area of 800 m<sup>2</sup>. Knowing that the aquifer would be unconfined, we can approximate the head difference (dh/dx) through the till as the surface gradient. Based on six transects on a 1:5000 map an average surface gradient of 0.047 was measured for the watershed.

#### Equation 5-1:

$$Q = K A d h/dx$$

Here Q is the total discharge through the basin, K is the hydraulic conductivity, A is the cross sectional area and dh/dx is the head difference, we get, for 1 year,

$$Q = K * (0.047 \text{ m/m}) * (800 \text{ m}^2) * (3.153 * 10^6 \text{ s/year})$$

$$Q = K * 1.1855 * 10^8 \text{ m}^2/\text{year}$$

We can consider a depth of runoff (d), given the area of the basin (A<sub>b</sub>),

$$d = Q/A_b$$

$$\approx K * 1.5 * 10^5 \text{ mm/year}$$

---

<sup>4</sup> Talisman (1995) gives a value for the watershed which is 2 times as large; all of their areas are most definitely two large by a factor of two.

Freeze and Cherry (1979) give a range between  $10^{-5} < K < 10^{-13}$  m/s for glacial tills. If we take  $K < 10^{-4}$  m/s,  $d < 15$ mm/year. This would be less than 1% of the annual rainfall. Therefore, we have assumed no loss of water to groundwater in the model. All the water in the basin flows through the soil or evaporates.

#### 5.4.4. A water balance approach

At the conceptual level the hydrology model is derived from a daily water balance approach. A water balance for a basin consists of a number of terms related to water inputs and outputs for a given area. For this study the water balance is constructed for two different areas. The first is the Beaver Lake watershed, the area that supplies water to the lake directly but does not include the lake itself. The second area is the lake. The interactions of the different terms of the model are summarized in Figure 5-2

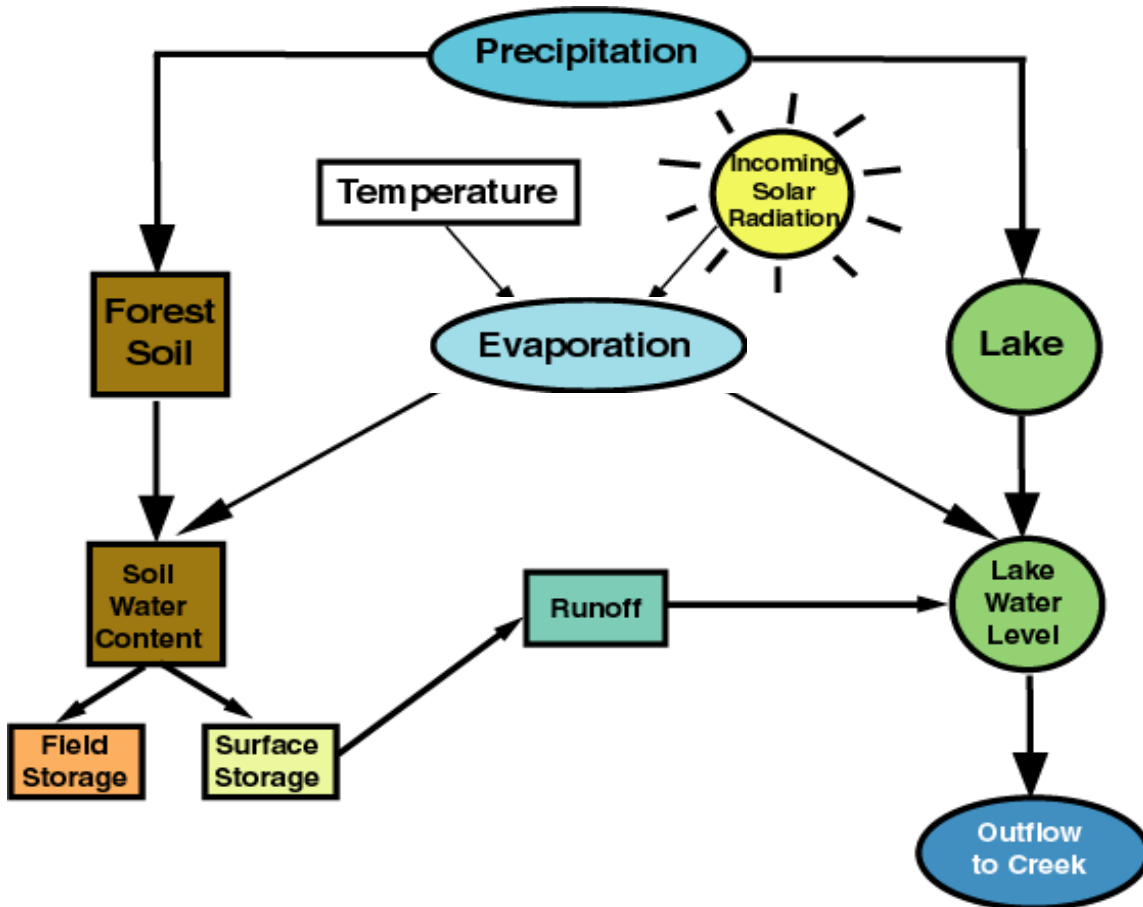

**Figure 5-2 Water movement through the model**

The first water budget (Equation 5-2) is for the watershed area and does not account for water being introduced artificially. It can be written as:

**Equation 5-2:**

$$\Delta S = P - E - Q$$

Here  $\Delta S$  is the daily change in water stored in the basin.  $P$  is the total daily precipitation,  $E$  is the total daily evaporation, and  $Q$  is the total volume of water that flows out of the basin in one day. This water balance is somewhat simplified and does not contain any terms accounting for rainfall interception (water which is trapped by vegetation or other structures and doesn't reach the ground surface), or for groundwater recharge. The basal till is shown to exist throughout the watershed on the Geological Survey of Canada map number 1586a (1979). This material is highly impermeable and it

is assumed no water is lost through it. The flow through the groundwater is probably less than 1% of the annual precipitation as calculated in section 4.3. The purpose of the water balance for the forest is to determine the daily runoff (Q). The model finds Q by entering precipitation from the data files, calculating evaporation and then updating soil storage. From soil storage the daily discharge can be calculated. This runoff value is used in the water budget for the lake.

The second water budget is for the lake. It can be written as:

**Equation 5-3:**

$$\Delta S = Q + P - E - F$$

Here  $\Delta S$  is the change in lake storage, Q is the runoff into the lake, calculated from the watershed water balance, P is the direct daily precipitation onto the lake, E is the daily evaporation, and F is the total volume of water which flows out of the lake on the given day. The purpose of the lake water balance is to predict the flow volume (F) into Beaver Creek from the lake (as opposed to the total outflow of the Beaver Creek watershed into the ocean). The model finds F by adding Q from the forest watershed above, entering the precipitation from the data files, calculating evaporation, and finding the change in lake depth from the height of the lake above the weir. The final output from the model displays the changing outflow level (F) and the changing lake depth on a graph over the time period chosen.

The following few sections detail how the model deals with each of the main terms in the water balance. They are laid out in the same order as that which is used to calculate runoff in the model, and thus begin with precipitation.

#### 5.4.5. Precipitation

Daily precipitation and maximum and minimum temperature measurement from the Environment Canada Harbour Center weather station were used in the model. These data were available for an eight-year period from September 1989 to October 1997, and were for the most part complete. For the three data sets the observations from December 11<sup>th</sup> 1990 to January 11<sup>th</sup> 1991 were missing and were replaced with the same dates from

the 1991-92 records. In the same manner the data from November 15<sup>th</sup> 1996 to November 30<sup>th</sup> 1996 were replaced with 1994 data from the same days. There were also a few days for which there were no data. For these days values were assigned that were representative of the season. Any snowfall that occurred during the measurement period was converted to its equivalence in rain by Environment Canada and was treated as rainfall within the model. Given the low frequency of snowfall in Vancouver and its usual rapid melt, this is not believed to be a problem.

The daily precipitation total is added to the soil water storage term which is kept track of as the model runs. The storage term is broken down into a number of different volumes for the model. Figure 5-3 is a hypothetical illustration of the volumes of water stored in the soil column.

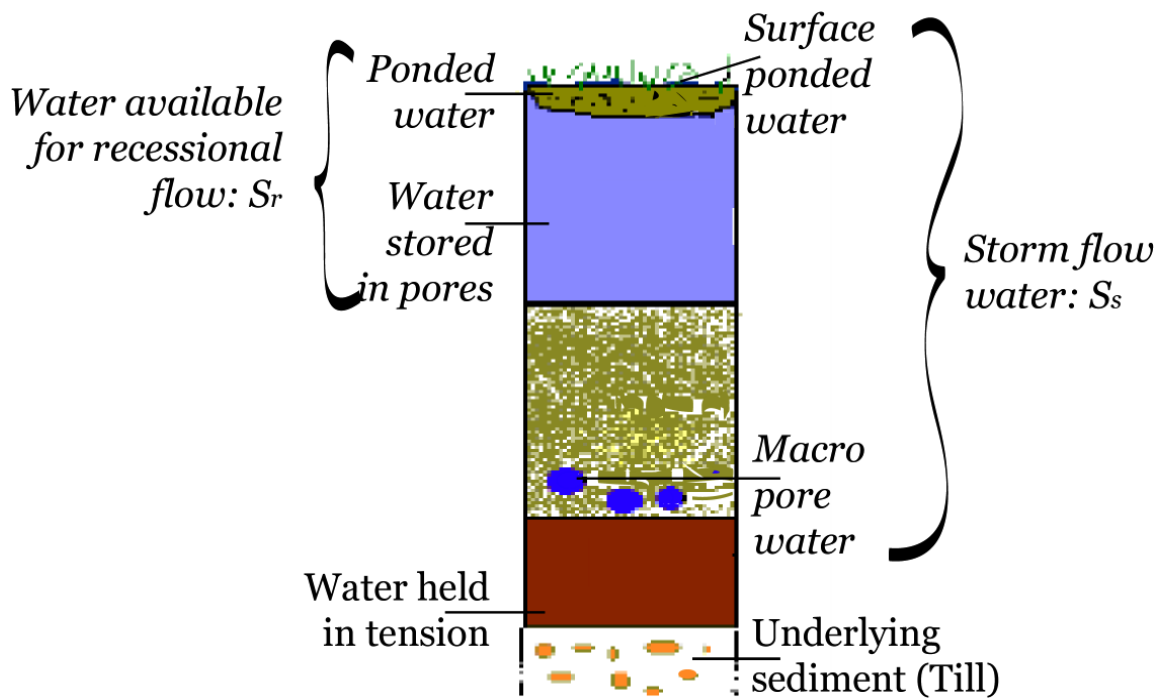

**Figure 5-3 Composite soil profile and associated water storage areas.**

**Equation 5-4:**

$$\Delta S = S_s + S_r + S_{fc}$$

Equation 5-4 breaks down the water storage term into three components:  $S_s$  - water which runs off as storm flow water (made up of both macro pore water and surface water),  $S_r$  - water stored and available to runoff over a number of days or weeks (made up of water ponded in depressions and water stored in pores), and  $S_{fc}$  - water which is stored in the soil after the water has drained. It is only withdrawn by evaporation or transpiration.  $S_{fc}$  includes the water which exists at or below the wilting point of plants. The upper limit on each of the storage terms is determined before running the model. Water held in tension ( $S_{fc}$ ) is limited by the field capacity, water stored and available to runoff ( $S_r$ ) is limited by the surface capacity (saturation capacity), and there is no limit on the amount of water which runs off as stormflow ( $S_s$ ).

The model first adds the day's precipitation total to the  $S_{fc}$  term, until the field capacity of the soil is reached. Once the  $S_{fc}$  volume is full the model then adds the precipitation to the  $S_r$  storage term until surface capacity of the soil is reached. Finally, once the surface storage term ( $S_r$ ) is full the remaining precipitation is added to the storm flow storage term ( $S_s$ ). This completes the addition of the precipitation term to the water balance. Following the addition of the daily rainfall the model makes a number of calculations to estimate a daily evaporation total.

#### 5.4.6. Evaporation

Evaporation is calculated for the watershed and for the lake separately. However, the basic approach to the calculation of daily evaporation is the same for both areas. The calculations make use of the Priestly-Taylor relation (Priestly and Taylor 1972, cited in Giles *et al.* 1985).

#### Equation 5-5:

$$E_{\max} = \alpha E_{\text{eq}}$$

Here  $E_{\max}$  is the maximum saturated daily evaporation,  $\alpha$  is an experimentally determined coefficient and  $E_{\text{eq}}$  is the equilibrium evaporation rate. It is  $E_{\max}$  which is used in the model as the amount of daily evaporation. In order to determine  $E_{\text{eq}}$  an energy balance approach was taken based on daily averages of incoming solar radiation

( $k\downarrow$ ) and minimum ( $T_{\min}$ ) and maximum ( $T_{\max}$ ) temperature values. The  $k\downarrow$  data from the UBC weather station was used and was available from September 1990 to September 1998. As with the precipitation and temperature data a few individual days had missing data. In these cases a representative  $k\downarrow$  was used.

The model uses an average daily temperature which is calculated using  $(T_{\max} + T_{\min})/2$ . In order to determine  $E_{\text{eq}}$ , the daily net radiation  $R_n$  needs to be determined.  $R_n = (1-a)k\downarrow + L^*$  where “a” is the albedo of the surface, and  $L^*$  is the net longwave radiation received at the surface. The albedo was estimated to be 0.12 for the canopy (Giles *et al.* 1985), and 0.07 for the lake (Dr. Tim Oke, personal communication).

$L^* = L\downarrow + L\uparrow$ , where  $L\downarrow$  is the incoming longwave radiation and  $L\uparrow$  is the outgoing longwave radiation.  $L\downarrow$  is calculated using  $L\downarrow = \epsilon_a \sigma T^4$  where  $\epsilon_a$  is the emissivity of the atmosphere,  $\sigma$  is the Stefan-Boltzmann constant and  $T$  is the air temperature (Stull 1995). To calculate  $\epsilon_a$ , we used the Idso-Jackson formula where  $\epsilon_a = 1 - (0.261 \exp(-7.77 * 10^{-4} (T - 273)^2))$  (Aase and Idso 1974, cited in Spittlehouse and Black 1981).  $L\uparrow$  is calculated using  $L\uparrow = \psi_s \epsilon_s \sigma T^4$  where  $\psi_s$  is the sky view factor (Arya 1988) which accounts for the influences of the trees along the edge of Beaver Lake.  $\psi_s$  equals 1 for the forested portion of the watershed and is estimated to be 7/8 for the lake based on the geometry of the lake and the height of the trees.  $\epsilon_s$  is the emissivity of the surface. A value of 0.95 is used for the emissivity of the vegetation in the watershed and a value of 0.97 is used for the emissivity of the water on the lake (Dr. Tim Oke, personal communication, 1999). For  $L\uparrow$  the air temperature is used for the vegetated portion of the basin, while the average air temperature from the preceding two weeks is used for the water temperature of the lake. Once the model calculates  $L^*$  it goes on to calculate  $R_n$  for the given day of the iteration.

$E_{\text{eq}} = (s/(s+\gamma)) * R_n / (L\rho_w)$  estimates  $E_{\text{eq}}$ , where  $s, \gamma, \rho_w$  and  $L$  are the slope of the saturation vapor pressure-temperature curve, the psychrometric constant at 100 Kpa, the density of water and the latent heat of vaporization respectively (Giles *et al.* 1985). The following equations for  $s/(s+\gamma)$  are noted to give less than 1% error and are used in the model (Viswanadham *et al.* 1991).

For  $0 < T < 16^\circ\text{C}$

$$s/(s+\gamma) = 0.407 + 0.0145 T \text{ (}^\circ\text{C)},$$

For  $16.1 < T < 31^\circ\text{C}$

$$s/(s+\gamma) = 0.483 + 0.0101 T \text{ (}^\circ\text{C)},$$

Once the model selects the appropriate  $s/(s+\gamma)$  value for a given day's average temperature, it goes on to calculate  $E_{\text{eq}}$ . Finally, the model needs to select an appropriate value of  $\alpha$  ( $=E_{\text{max}}/E_{\text{eq}}$ ) by examining the soil water content for the vegetated portion of the model and the season of year for the water balance dealing with the lake.

For the vegetated portion of the model  $\alpha$  is largely based on the work of Giles *et al.* (1985) and Black (1979). They have found that  $\alpha$  maintains a constant value until some critical water storage content ( $\theta_{\text{ec}}$ ) at which time it linearly decreases in value with decreasing soil water storage. Black (1979) notes that Tanner and Ritchie (1974) converted soil water content data to a fractional extractable water content ( $\theta_e$ ) which is defined as follows:  $\theta_e = (W - W_m)/(W_f - W_m)$ . Here  $W$  is the root zone water storage,  $W_m$  is the water storage at the permanent wilting point, and  $W_f$  is the field capacity of the soil. The model keeps track of mm of water/m<sup>2</sup>, and as such does not keep  $W$  in dimensionless units. Black (1979) divides the water storage depth by the root zone depth to achieve dimensionless values of  $W$ . The model does not complete this step as it can be observed that  $\theta_e$  comes out as a dimensionless number in the above relation as long as all watershed storage terms are in the same units. Thus the model avoids the problem of determining a root zone depth for the watershed. The soil water storage term  $S_{\text{fc}}$  is equivalent to  $W$  such that  $W = S_{\text{fc}}$ .  $W_m$  was estimated to be 40mm for the basin based on the soil characteristics and typical values of permanent wilting points (Tim Ballard, personal communication).

The model makes use of the  $\alpha$  values and  $\theta_{\text{ec}}$  determined by Giles *et al.* (1985) who performed their field work at the east end of Cowichan Lake in a forest which is believed to have similar characteristics to that of Stanley Park. In order to determine  $\alpha$ ,  $\theta_e$  was normalized by  $E_{\text{eq}}$  for the given day of the iteration. Giles *et al.* (1985) determined  $\alpha = 0.73$  for  $\theta_e/E_{\text{eq}}$  greater than  $0.178 \text{ (mm/day)}^{-1}$  as displayed in Figure 5-4. The linear

relation which reduced  $\alpha$  once  $\theta_e/E_{eq}$  fell below  $0.178 \text{ (mm/day)}^{-1}$  was determined to have a slope of  $4.1 \text{ mm/day}$  and went through the origin. Thus for any value of  $\theta_e/E_{eq}$  less than  $0.178$  the value of  $\theta_e/E_{eq}$  is multiplied by  $4.1 \text{ mm/day}$  to give the daily value of  $\alpha$ . This value is then multiplied by  $E_{eq}$  to give the daily total evaporation over the forested area of the watershed.

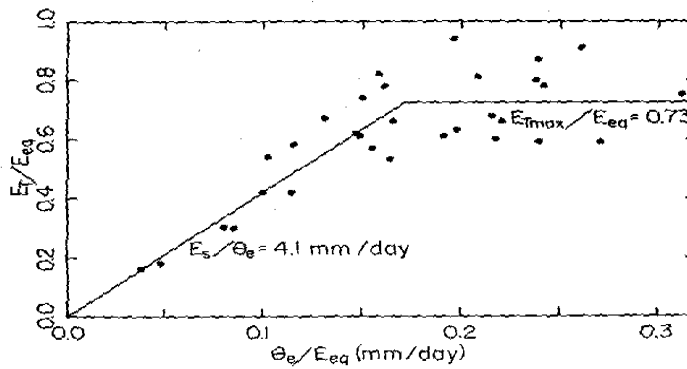

**Figure 5-4** Giles *et al.* (1985) data for  $\alpha$  as a function of  $\theta_e/E_{eq}$

$\alpha$  for Beaver Lake is substantially more straight forward. For water bodies  $\alpha=1.26$  is commonly used (Tim Oke, personal communications). The lilies complicate matters in the summer months because part of the leaves are dry on top of the water surface, and thus the actual evaporation is lower compared to a free water body. To correct for this a value of  $\alpha=1.1$  was used for the months from June through September. Once the model determines which  $\alpha$  was correct for the given season it goes on to calculate the actual daily evaporation ( $E_{max}$ ).

The daily value of evaporation is first subtracted from the  $S_r$  term if there is any water stored in this portion of the soil. If the  $S_r$  term is zero, the model subtracts evaporation from  $S_{fc}$  storage term. Once the evaporation is removed from the appropriate water storage terms, the daily total runoff from the watershed can be determined.

#### 5.4.7. Stream Runoff

Peak stream discharge occurs immediately after storm events and may last for a day or two in basins like Beaver Creek (Knighton 1998). These flows are characteristically labeled stormflows (*Ibid.*). Given that the Beaver Creek watershed is extremely small and the longest distance to a channel is approximately 500m, the storm flow is considered to leave the basin on the same day as the precipitation event.

The water which is subsequently left in the soil is made up of both water held in tension and water able to drain. The water able to drain is characterized as shallow base flow water and may flow out of the basin in the logarithmic recessional form shown in Equation 5-6 (Anderson and Burt, 1980).

##### **Equation 5-6:**

$$Q = Q_0 e^{-kt}$$

Here  $Q$  is the flow at a given point in time,  $Q_0$  is the flow at the start of the recession,  $k$  is the recession constant and  $t$  is time. The longer the stream flow recession is the smaller  $k$  is and more water will be running off later in time. This relation is key to the model and it is useful to make a few cursory comments about its origins and validity.

The relation originated with the work of Barnes (1939) and was originally expressed by Barnes in the form

##### **Equation 5-7:**

$$Q_t = Q_0 k^t$$

It is noted to have a logarithmic discharge scale and an ordinary time-scale. The constant “depletion factor”  $k$  in Equation 5-7 is different in value than the recession constant in Equation 5-6; however, they represent the same recessional characteristics for a particular basin (Anderson and Burt, 1980). For the remainder of the paper “ $k$ ” will mean the recession coefficient as defined in Equation 5-6.

Barnes’ original measurements can be split into three different  $k$  values: one corresponding to overland flow, a second corresponding to subsurface stormflow and a third corresponding to baseflow (Anderson and Burt 1980). Each of these has a characteristic time scale, namely a few days, 10-14 days and a couple of months

respectively. These values do depend on the scale of the basin, a basin. For our model we are only looking at the intermediate time scale. The shallow soil (estimated to be on the order of 0.5 meters thick) overlying the impermeable till does not have the resources to develop a significant baseflow, and as a consequence it is only the soil water which is important in streamflow recession.  $k$  itself has been shown to depend on mean land slope, drainage density, and the ratio of hydraulic conductivity and drainable porosity (Zecharias and Brutsaert, 1988) and as such it is expected to be spatially variable, yet constant for a particular basin.

Our  $k$  value was determined by measuring the discharge from a PVC pipe which goes under the ravine trail and flows directly into Beaver Creek. The measurement site is given as point A on Figure 4-1. This creek is completely outside of the watershed modeled, but has similar soils, slopes and aspect. It was chosen as it is not affected by the city water supply and is sufficiently small that it could be gauged with a 10 liter bucket twice a day. A five day clear spell in December following a month or so of rain presented us with a well saturated basin. From this we made discharge measurements to calculate  $k$  (the data is contained in the appendix). It is important to note that the temperature was below zero for most of the days during the discharge sampling and consequently evaporation was effectively zero. However, at no time did the ground itself become frozen and thus hold frozen water in the soil. We were unable to gauge the runoff for more than five days because it snowed and we did not get the chance to observe the recession over a longer period of time. However, the available data are exceptionally linear as seen in Figure 5-5 with an  $R^2$  value of 0.9955, indicating that the sampled basin behaved according to a single  $k$  value. In these calculations the first measurement was not used as it was likely still influenced by the stormflow from the preceding evening's rain. Stormflow would have a different value of  $k$ , but would likely exist for less than a day in a basin as small as the Beaver Lake watershed.(Barnes 1939). As the model works in day units there was no attempt to calculate the stormflow  $k$  value.

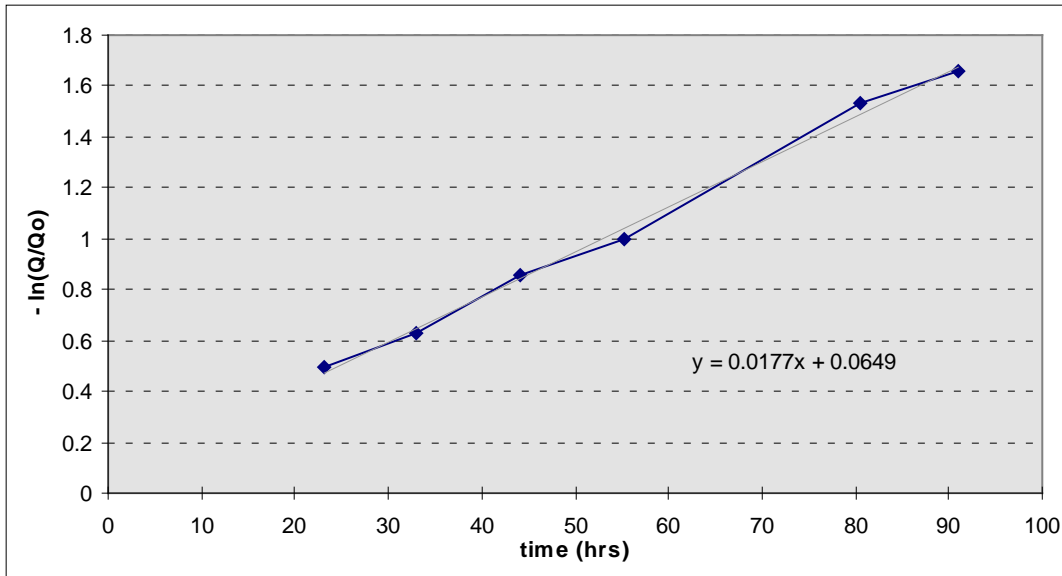

**Figure 5-5 Stream flow recession data for the Beaver Creek watershed**

Our observations of the declining lake level during the gauging period indicate that a  $k$  value measured from Beaver Creek would be similar to the one we measured from the discharge of the small tributary. The Beaver Lake watershed is larger than the watershed feeding the tributary from which we measured our  $k$  value. Generally one would expect the  $k$  value to be smaller for the larger basin, as it takes longer for the water to move through the larger basin. However, the channel extensions within the Beaver Lake watershed will reduce the recession time for the basin and may leave the  $k$  value relatively unchanged. A future study evaluating the recession constant for the Beaver Lake watershed could confirm our estimation that the  $k$  value is around  $0.425\text{day}^{-1}$ .

For comparison sake it is interesting to note that Barnes' value for  $k$  for subsurface stormflow was  $0.366\text{day}^{-1}$  (Anderson and Burt 1980), while ours is  $0.425\text{day}^{-1}$ . These different values are to be expected given the differences in basin characteristics<sup>5</sup>. However the fact that they are of a similar magnitude indicates that they represent the same runoff processes.

In theory it is possible to predict the recession of runoff ( $Q$ ) from one day to the next once the initial flow is known. However, the initial flow is a challenge to model, as

<sup>5</sup>. Hatfield (1985) gives values between 0.35-0.65 for the runoff coefficient, which is a different constant than the  $k$  defined above.

it has to be derived from the stored volume of water in the soil. Depending on the amount of water in  $S_s$  and  $S_r$ , the discharge for a given day is calculated somewhat differently.

If  $S_r$  is full there is a maximum value of runoff which can come from this amount of storage. If  $S_s$  is greater than this amount of runoff then  $S_s$  is the amount that runs off on that day. If  $S_s$  is greater than zero then the amount which runs off equals the amount able to runoff when  $S_r$  is full. When this is done  $S_s$  is zero at the end of the day, and the amount of water which ran off, but did not come from  $S_s$  is subtracted from  $S_r$ . In order to calculate this maximum discharge it is necessary to digress into some more theory about recession flows.

The model is designed to calculate the runoff for a given day based on the water available to run off for that given day. For any given day there is some remaining water which does not run off. It forms the starting  $S_r$  value for the subsequent day and the evaporation is subtracted from this value if no precipitation occurs on the day. After this subtraction is performed, a new runoff value is calculated from the new  $S_r$ . Equation 5-8 expresses this process.

**Equation 5-8:**

$$S_{rD2} = S_{rD1} - Q_{D1} - E_{D2}$$

Here  $S_{rD1}$  is the soil storage which is available to runoff on day 1, and  $Q_{D1}$  is the runoff on day 1.  $E_{D2}$  is the evaporation on day 2, which has already been calculated in the model.  $S_{rD2}$  is the soil storage available to runoff on day 2 assuming it has not rained.

The runoff value is recalculated each day based on the stored water that is available to runoff, rather than the flow of the preceding day; consequently, the resulting flows are not related in a typical recession manner. When examining recession flow it is common to relate the flow of subsequent days to the flow on the initial day. In the model the logarithmic recession flow relation (Equation 5-6) is used to relate the storage of a given day to that days flow. To do this we need to recognize the following:

**Equation 5-9:**

$$F_D = \int_0^D Q_0 e^{-kt}$$

Here  $F_D$  is the total flow from time = 0 to time = D based on Equation 5-9 which gives the instantaneous flow at a given point in time. Integrating Equation 5-8 we find

**Equation 5-10:**

$$F_D = Q_0/k(1 - e^{-kD})$$

We also know that the total amount of storage ( $S_T$ ):

**Equation 5-11:**

$$S_T = \int_0^{\infty} Q_0 e^{-kt}$$

which can be integrated to give:

**Equation 5-12:**

$$S_T = Q_0/k$$

Solving Equation 5-12 and Equation 5-10 for  $S_T$  and  $F_D$  in terms of k we get

**Equation 5-13:**

$$S_T(1 - e^{-kD}) = F_D$$

which lets us calculate the daily runoff. By assuming that  $S_r = S_T$ , which corresponds with our definition of  $S_r$ , we can find the total flow from time = 0 to time = D. We can now calculate the daily flow for a given  $S_r$  value. This completes the computations for the forested watershed portion of the daily model resulting in a total runoff which reaches the lake. Once the flow into the lake occurs,  $S_r$ , the water in the soil available to runoff, is recalculated with Equation 5-8 using the evaporation for the next day.

#### 5.4.8. Inputs into the lake

The model runs for the land portion of the watershed first and calculates all the aforementioned variables. At the end of this it has a daily runoff and residual soil water storage terms expressed as water depth (m). The runoff term is multiplied by the area of the basin and then added to the volume of water in the lake. The water storage terms are kept track of until the next day when they form the basic starting volumes. The lake portion of the model then runs for the given day.

#### 5.4.9. The modeling of lake outflow

The lake level and outflow volume portions of the model are highly integrated. Because the level of the lake determines the total volume of outflow, the lake level is updated on an hourly basis throughout the day. Each time the lake level is updated, a new outflow volume is calculated. At the beginning of each day, the total evaporation from the lake is removed and precipitation into the lake is added for the entire day. The amount of runoff from the basin,  $Q$  from Equation 5-2 is divided into 24 equal segments of hourly inflow to the lake. This assumes that the inflow is constant over the day. The volume of water in the lake is recalculated every hour using the following balance:

**Equation 5-14:**

$$\Delta S = I - O$$

$\Delta S$  is the change in water stored in the lake,  $I$  represents the hourly inflow and  $O$  represents the hourly outflow.

In order to determine the lake level, a relationship between the volume and the depth of Beaver Lake was found. From the bathymetric survey completed by (Stewart 1997), the surface area relating to each depth contour was found using a polar planimeter. The depth contours have been re-drafted on Figure 6-2 . The depth contour increment on the survey was 0.3m. Table 5-1 shows the surface area of the lake that would be present for a given lake depth. A polynomial equation was fit to a plot of area vs. height shown in Figure 5-6.

**Table 5-1 Depth - surface area relation.**

Elevation above mean sea level (m) (Stewart 1997)	Lake depth at deepest point (m)	total area (m <sup>2</sup> )
36.02	0	0
36.3	0.28	2820
36.6	0.58	13670
36.9	0.88	27320

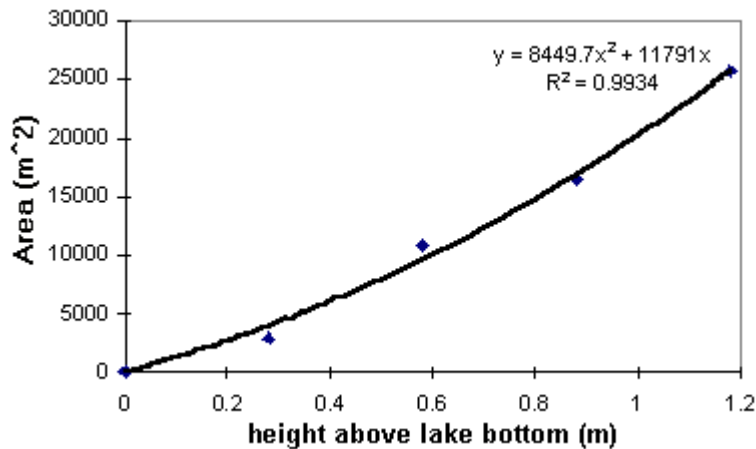

**Figure 5-6 Area - depth relation**

In order to relate lake storage volume to the depth, the equation in Figure 5-6 was integrated with respect to depth. This gave us Equation 5-15 with storage in m<sup>3</sup> and depth in meters above the lowest point in the lake (36.02m).

**Equation 5-15:**

$$S = 2816.5d^3 + 5895.5d^2$$

The model uses Equation 5-15 with an updated storage based on Equation 5-14 to recalculate the depth every hour in order to determine the runoff out of the lake. We Equation 5-15 for depth as a function of storage graphically. We graphically solved Equation 5-15 for depth as a function of storage. The graphical results are shown in Figure 5-7.

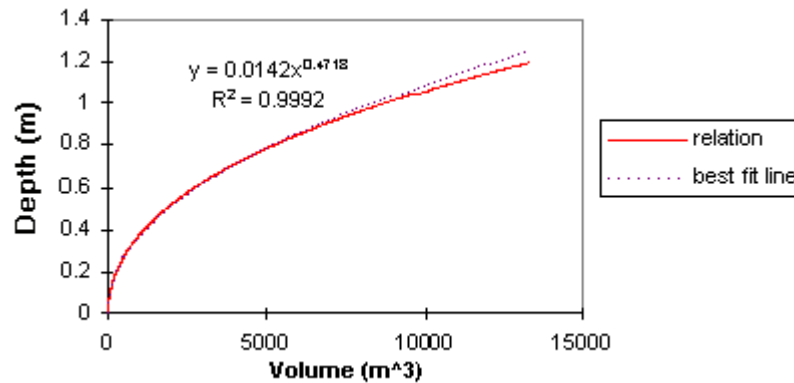

**Figure 5-7 Depth-volume relation**

Once the depth of water is known it is used to calculate the outflow from the lake. In Beaver Lake there are two culverts through which water leaves the lake. These are shown in plan view in the appendix. The main outflow weir is shown in Figure 5-8.



**Figure 5-8 Main weir on Beaver Lake**

The base of this weir is 1.165 meters above the lowest point in the lake. In order to determine the outflow of the main weir standard weir equations were used. These are designed for weirs of much more uniform dimensions and thus only approximate the outflow of the lake. While the main weir is trapezoidal in shape, it does not have side

walls with a ratio of 1 horizontal to 4 vertical which is the standard against which trapezoidal weir equations have been generated. The weir also has a grate along the front of the structure which will act to reduce the flow through the structure. As a result of these two factors we chose to model the weir as a rectangular weir. Wu *et al* (1999) estimates the main weir has a maximum capacity of 0.6 m<sup>3</sup>/s and this was accounted for in the model.

The secondary weir is estimated to have a maximum discharge of 0.13 m<sup>3</sup>/s (Wu *et al.* (1999) and was also modeled as a rectangular weir. Figure 5-9 is an end-view of the downstream side of the culvert and the elevations are tied in to the survey completed by Stewart (1997). The inflow height of the culvert was used as the height of the weir (1.10 m) and it was assigned a width of 0.4m. Equation 5-16 is the equation used to model rectangular weirs (Stevens) and is present in the form where Q is the discharge (m<sup>3</sup>/s), w is the width of the weir (m) and h is the water head (m). The head is calculated by subtracting the height of the weir from the depth of water in the lake. If the head for a weir is negative, no water flows out of the weir.

**Equation 5-16:**

$$Q=6.0318(w-0.2h)h^{3/2}$$

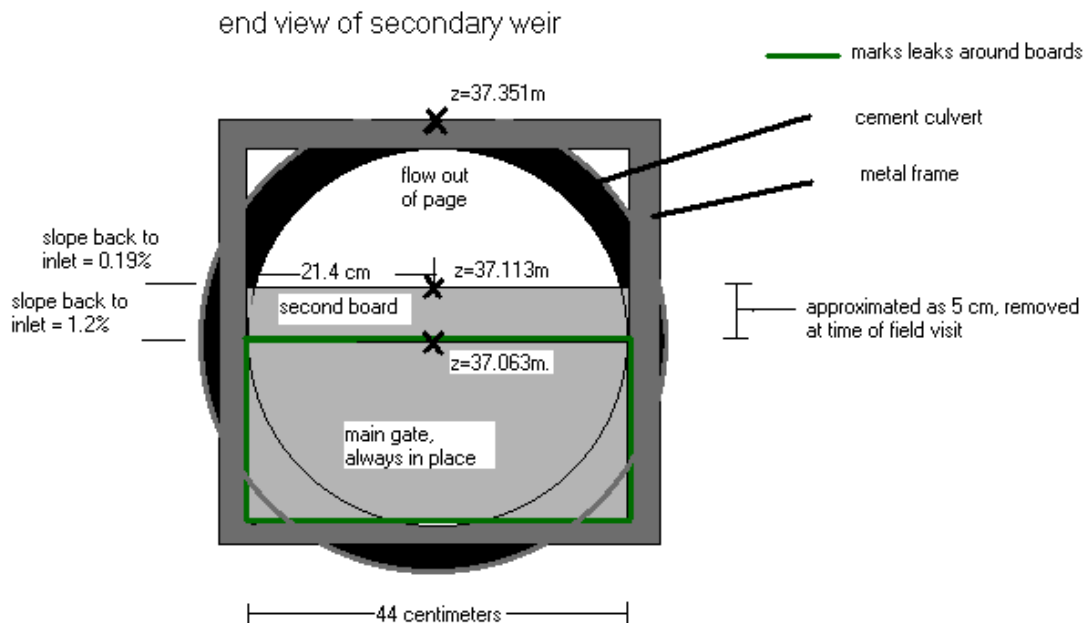

### **Figure 5-9 End view of secondary culvert**

Throughout the day the total outflow leaving the lake and the water level of the lake are recorded. The model can display the daily totals in numerical and graphical formats.

#### **5.4.10. Starting parameters for the model**

The starting simulation window is shown Figure 5-10. In this window, start and end dates, initial field storage and field capacity values, and the initial lake water level are chosen. The field storage and surface storage can be set to any value between 0mm and the field capacity and surface capacity, respectively. The lake level is with reference to the deepest point in the lake, which has an elevation of 36.02m (Stewart 1997) above sea level, and is suggested as 1.2m to start the model.

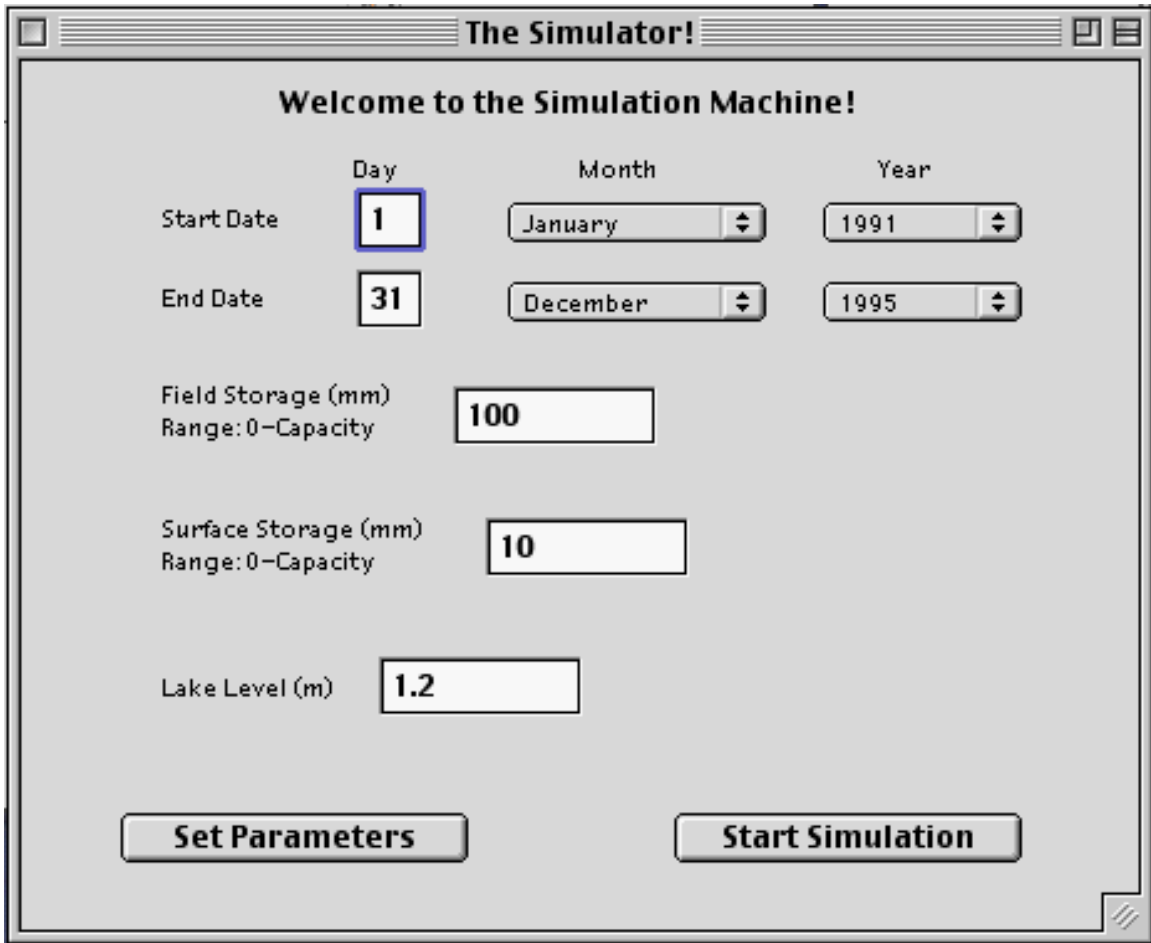

**Figure 5-10** The model’s pre-simulation window

If the “Set Parameters” button is chosen in the starting simulation window, a second window will appear as shown in Figure 5-11. In this window, the most important parameters, which determine the outcome of the model, can be changed. The initial values that appear in the boxes are the ones the model uses unless the user makes any changes. Note it is also in this window that the user can add city water if it is desired. It has been estimated that the pipe flowing into Prospect Creek contributes  $0.184 \text{ m}^3/\text{s}$  (Wu *et al.* 1999) to the basin, and this is the value we used in the runs where artificial water was added.

Set Parameters	
Artificial Water Supply (m <sup>3</sup> /s) <input type="text" value="0"/>	k (/h) <input type="text" value="0.0177"/>
Surface Capacity (mm) Range: 250-300 <input type="text" value="150"/>	Alpha zero slope value <input type="text" value="0.73"/>
Field Capacity (mm) Range: 150-250 <input type="text" value="100"/>	crucial point (mm) <input type="text" value="0.178"/>
Permanent Wilting Point (mm) Range: 30-60 <input type="text" value="40"/>	slope (day/mm) <input type="text" value="4.1"/>
<input type="button" value="Finished"/>	

**Figure 5-11 The “Set Parameters” window in the model.**

#### 5.4.11. Results of the model

Several runs of the model were performed in order to obtain reasonable starting parameters. The field capacity was first estimated at 150mm, yet it was discovered that water was not filling the field capacity throughout wet winters as would be expected. Therefore, the field capacity was adjusted to 100mm. This seems more likely since the depth of the soil throughout the watershed is on the order of half a meter. The surface capacity was reduced from 250mm to 150mm because even during the wettest times. The surface storage only reaches 100mm. However, it is not expected that the surface capacity be exceeded at any point during an average winter for an entire day. Overland stormflow in a forest soil is only expected to occur during very large storm events. The lake level was left at 1.2m as the starting parameter since this is a reasonable mid-winter

lake level according to the runs we did. Once all of these initial parameters were chosen, several scenarios were run.

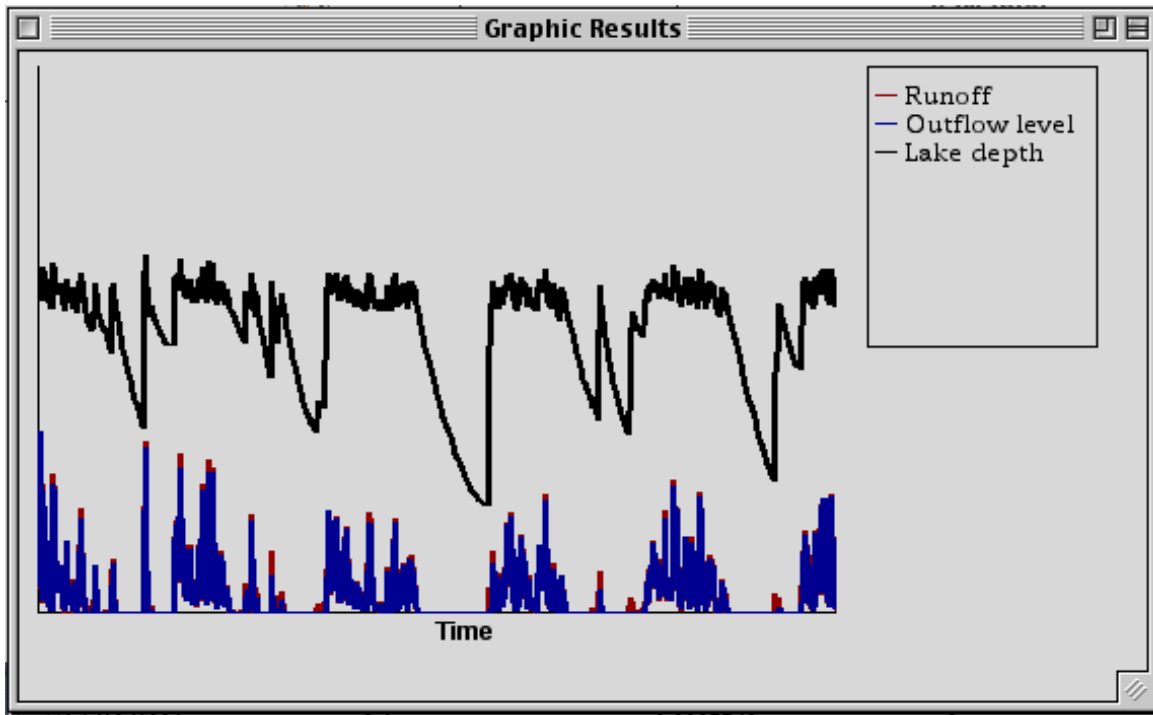
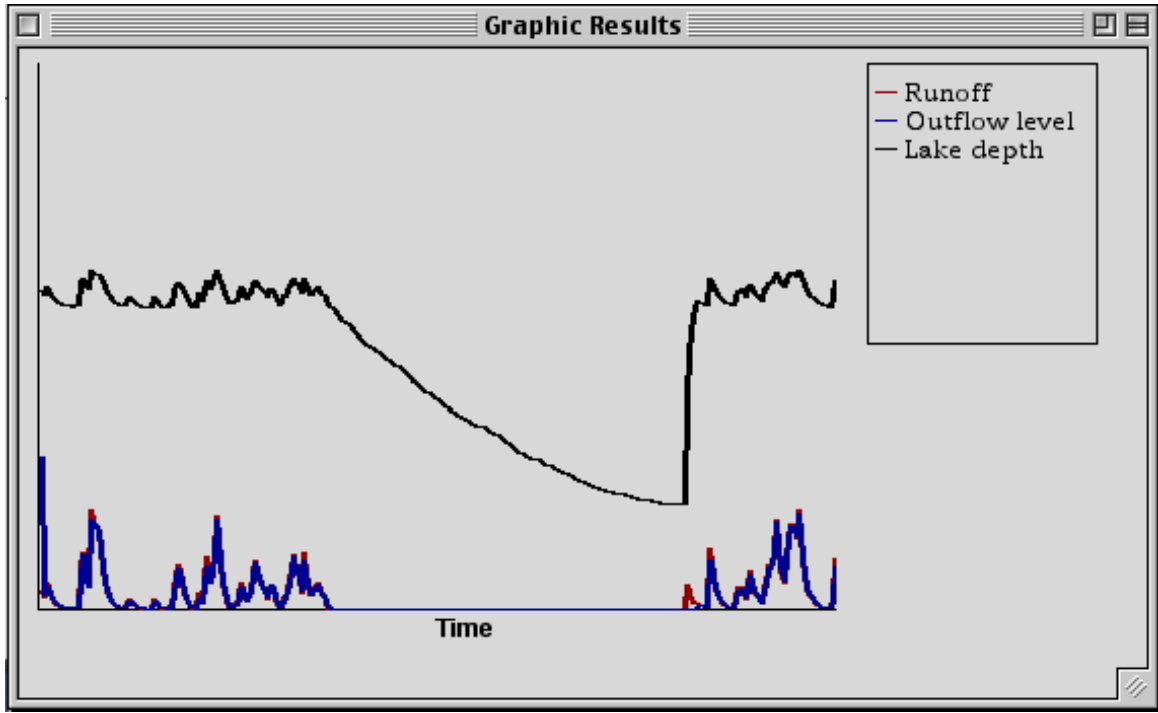

**Figure 5-12 Five-year run: no city water (Jan. 1, 1991 – Dec. 31, 1995).**

The first scenario was simply a five-year run of the model to see the effect of completely removing the city water. The graphical results are shown. As well as graphical results, a table of daily values reporting the precipitation, field storage, surface storage, soil evaporation, runoff, and lake level was displayed. The general trend is easily read from the graphical results. The lake level remains quite high and consistent throughout the winter months. From the numerical results, the actual depth (measured from the deepest point in the lake) varies between 1.2m and 1.3m. Similarly, the outflow level and runoff are quite high throughout the winter months. The outflow level is closely related to the runoff because the lake is very small and does not act as much of a buffer, particularly when it is at capacity already. As summer approaches each year, precipitation lessens and the amount of runoff leaving the soil drops. As the runoff drops, the lake begins to draw down. Out of the five-year record that we had data for, the summer of 1993 indicates the most severe drawdown. Here the lake level reaches as low

as 0.4m from the deepest point. Generally, the summer drawdown results in a lake level of 0.6m by mid- to lake-August.

The next scenario run was a one-year run, to show the effect of the lake drawdown in more detail. Figure 5-13 shows this for 1993. Here the lake level draws down below the outflow weir level in late-June and remains below that level until late-September. Therefore, for approximately three months there is no outflow into Beaver Creek.



**Figure 5-13 One-year run: no city water (Jan. 1, 1993 – Dec. 31, 1993)**

The third scenario was an attempt to model the present conditions. Here the artificial water supply was added into the model to see the results. No verification could be made of the estimated outflow volumes because no streamflow data has been collected. However, it is known that the lake level varies approximately 10cm and remains above the main weir height all year long. The results of adding city water can be seen in Figure 5-14.

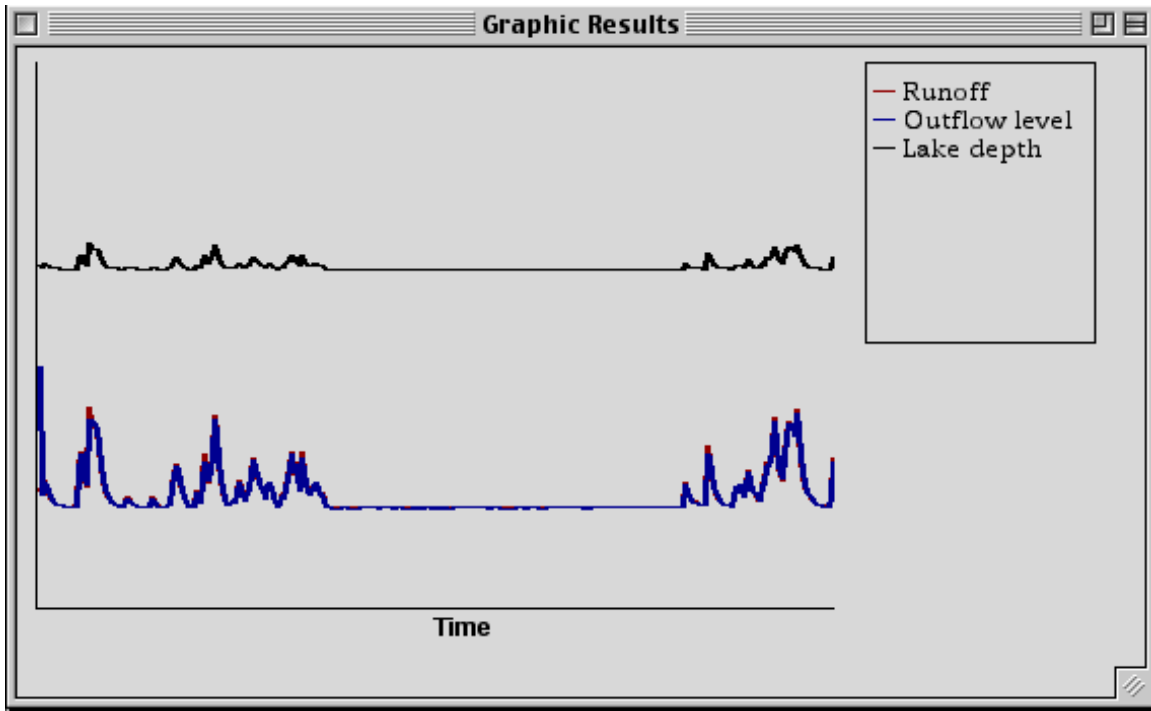
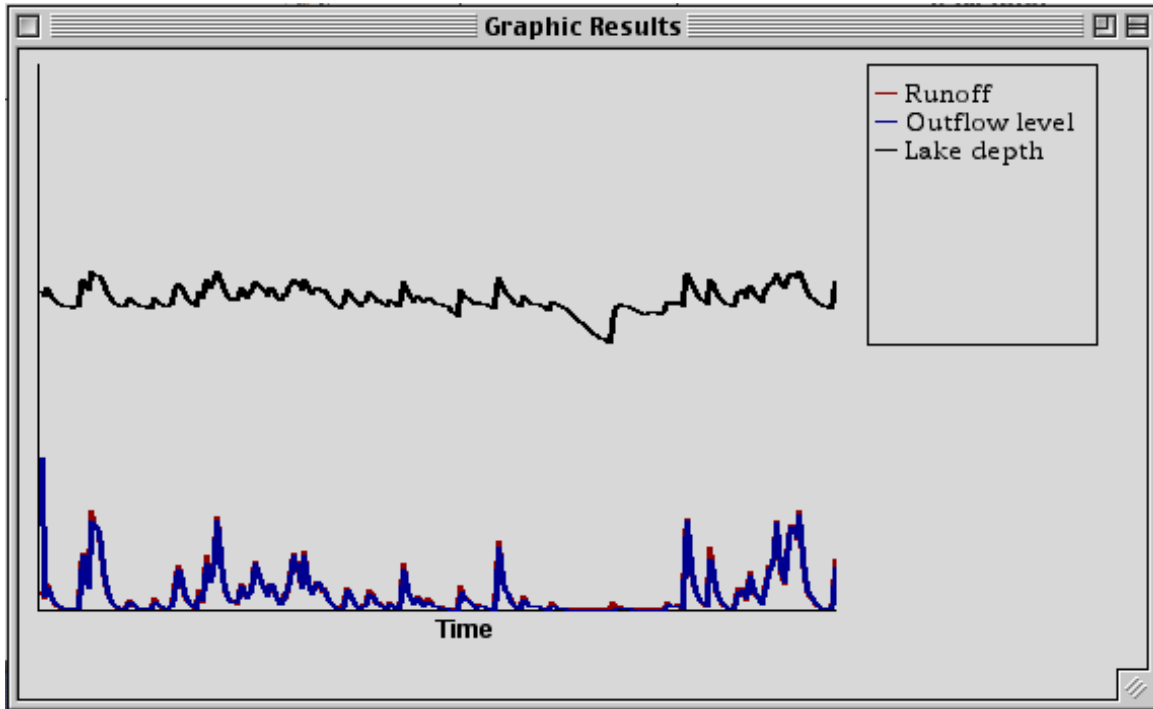

**Figure 5-14 One-year run: artificial water supply (Jan. 1, 1993 – Dec. 31, 1993)**

As expected, the lake level remains above the weir level all year-round. Furthermore, in the winter months the lake level is raised when large storms occur. These fluctuations correlate with the peak runoffs from the soil. The fluctuations stay within a 15cm range. The outflow volume going into Beaver Creek also fluctuates during the winter months and remains above a certain base level throughout the summer months.

The final scenario run was a removal of all soil evaporation from the model. As described earlier, most hydrological models ignore soil evaporation because it is difficult to measure and is usually insignificant in reporting high flood levels. This scenario shows what would happen if soil evaporation in our model was ignored, and the results

can be seen in Figure 5-15. Clearly the soil evaporation is a significant factor in determining the summer lake level. When we ignore it, the drawdown in the lake is very mild, and the outflow to Beaver Creek only stops for three weeks in late-August and early-September. Evaporation from the lake is still being accounted for in this run.



**Figure 5-15 One-year run: no evaporation (Jan. 1, 1993 – Dec. 31, 1993)**

#### 5.4.12. Discussion of the model

Generally, the results of the model indicate that the lake would be drawn down approximately 60cm during a typical summer and the outflow to Beaver Creek would stop for approximately three months. How accurate are these results? As was mentioned above, validation of the model is nearly impossible because no streamflow data for Beaver Creek is available (either with the artificial water supply or without). Therefore, the accuracy cannot be measured directly. However, a look at the resulting values and a comparison with other watersheds may give us some idea of the accuracy of the results.

First, the runoff values. The runoff values are on the order of  $0.01\text{m}^3/\text{s}$  –  $0.1\text{m}^3/\text{s}$  during the winter months. Data gathered from Jamieson Creek, in the GVRD watershed, by Dr. M. Church (personal communications-b) in October of 1971 indicates that runoff

values are on the order of  $0.05\text{m}^3/\text{s} - 1.5\text{m}^3/\text{s}$ . As expected, the Jamieson Creek runoff values are quite a bit larger than the model calculations, since the Jamieson Creek Watershed is approximately 300Ha in size – four times larger than the Beaver Lake Watershed. Therefore, the runoff estimates seem to be reasonable given the small size of the watershed.

Second, the outflow values. These closely mimic the runoff values because Beaver Lake is quite small and cannot act as much of a buffer. The fact that the outflow stops for three to five months every year is not surprising. Cutthroat Creek in Pacific Spirit Park (UBC Endowment Lands) dries up annually for the summer (M. Church, personal communication) and its catchment basin is quite a bit larger than the Beaver Lake watershed. Therefore, given the precipitation patterns for Vancouver, it would be expected that Beaver Creek would dry up for at least two months without the addition of an artificial water supply. Furthermore, due to the height of the weir, the outflow into Beaver Creek will stop earlier and return later than would be expected in the system without the weir. Therefore, an estimate of three to five months without any outflow seems reasonable.

Third, the evaporation values. As described earlier, the Priestly-Taylor method of calculating evaporation was used. Whenever these calculations gave negative evaporation, a result of negative net radiation, the evaporation was set to zero. Validation of the evaporation values calculated in the model is very difficult because evaporation data is not available for the area. A comparison can be drawn between the results of the Priestly-Taylor method of calculating evaporation and field measurements taken by Elyn Humphreys, a graduate student in Soil Science. A ratio between the incoming solar radiation and evaporation data gathered in Campbell River in a forest environment, which is comparable to the forested region of the Beaver Lake watershed, was calculated on a monthly basis. The aim is to be able to estimate evaporation given the solar radiation data and the monthly ratio. This data is in early stages of evaluation, but provides a reasonable comparison for the results from the model.

Figure 5-16 shows the results of the model evaporation compared to the data gathered from Campbell River. The summer relationship from the Priestly-Taylor

calculations (in the model) matches quite well with the Campbell River data from the summer. This confirms that our summer evaporation data are reasonable when compared to collected field data. However, there are large discrepancies between the winter relationships. This large discrepancy is not a large concern to the overall results of the model because it only affects the winter evaporation values which are negligible in determining the summer lake level and outflow level. The discrepancy does have implications for future calculations of evaporation in a forested environment. The use of the Priestly-Taylor method should be limited to spring, summer and early fall months.

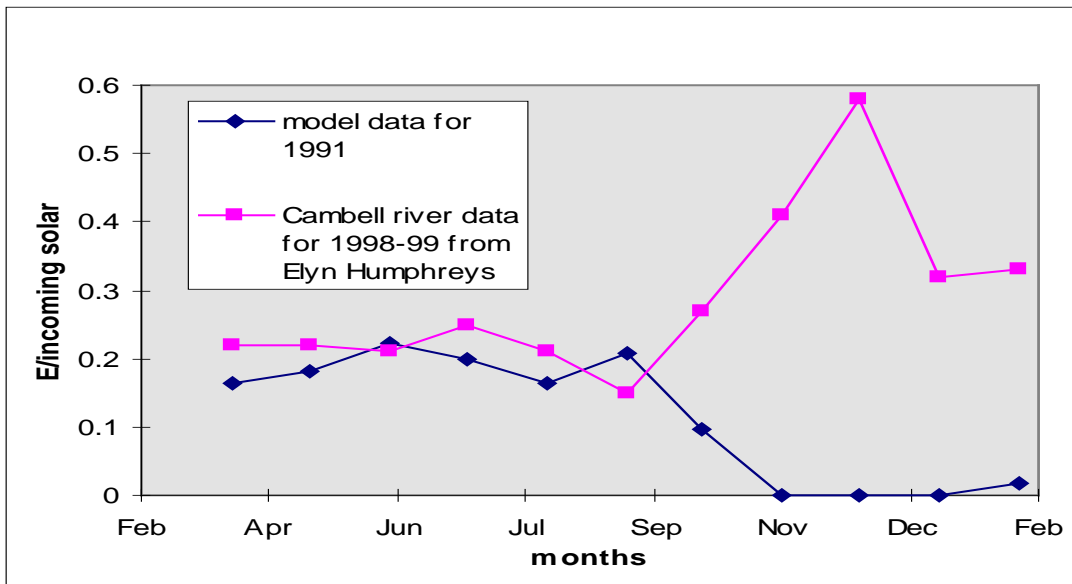

**Figure 5-16 Ratio of 24-hour Evaporation to Incoming Solar Radiation**

Through validation of the runoff values with the Jamieson Creek runoff values, outflow levels with the Cutthroat Creek outflow levels, and evaporation values with data from Campbell River, the model results are reasonable. The drawdown of the lake by late-summer is likely on the order of 50-70cm, and the outflow likely stops for approximately three to five months if the artificial water supply is completely removed.

## **6. Analysis of the lake Sediments**

The research team took a number of cores from Beaver Lake to evaluate the sediment record. We were particularly interested in the sedimentation rate, type of sediment and metal concentrations in the lake. The information gathered is used to make recommendations about the future management of the Beaver Lake watershed.

### **6.1. Field visit**

A small boat was put on the lake on a rainy day in mid October to take the sediment cores.

#### **6.1.1. Field methods and materials**

Two stations on the lake (A and B) were chosen to take the core samples. To locate the stations, two reference points were used: the outflow gate to Beaver Creek, and the large cedar tree in the cleared area south-east of the lake. See Figure 6-2 for the positioning of the two stations. Site A was close to the center of the lake in an area adjacent to a large growth of lilies. Site B was located on the west side of the lake in an area of open water with few lilies.

A Hiller corer and a Livingston corer were used at each site to collect samples of different sizes from different depths (see Table 6-1). Procedures to extract the cores were specific to the type of corer used.

**Table 6-1 Core samples and field sample lengths**

	<b>Hiller Corer</b>	<b>Livingston Corer</b>
<b>Depths Sampled at site A</b>	AH1: 0 - 0.5m	AL1: 0 - 0.85m
<b>Depth of water at site</b> <b>A=0.70m</b>	AH2: 0.5 - 1m	AL2: 0 - 1m
	AH3: 1 - 1.5m	AL3: 0 - 0.95m
	AH4: 1.5 - 2m	AL4: 0 - 1m (moist length = 0.475m)
	AH7: 3.5 - 4m	
<b>Depth sampled at site B</b>	BH1: 0 - 0.5m	BL1: 1.05m (moist length = 0.686m)
<b>Depth of water at site</b> <b>B=0.73m</b>	BH2: 0.5 - 1.0m	
	BH3: 1 - 1.5m	

The Hiller corer was used to take a series of samples at the same position in the lake from different depths. In order to maintain the same hole for reentry, two support tubes, as shown in Figure 6-1 (approximately 8 feet long) were placed into the surface sediment and were installed such that they did not immediately become filled with water.



**Figure 6-1 Taking a sample with the Hiller Corer**

The position of the sample was controlled such that successive 50 cm depths were sampled using the top of the PVC pipes as a reference. The door on the sampler was opened once it was at the proper depth and then closed before it was pulled up from the sampled depth. The sample was carefully scraped into a double layer of plastic wrap, rolled up (burrito-style), labeled, and rolled in a layer of aluminum foil.

The Livingston corer was used to take a larger sample from 1m below the surface. Vacuum tubes (1.5 inches in diameter) with sediment catchers placed in the bottoms were used to collect the sample. The corer was dropped and then pushed vertically into the sediment until it would not go any further. The corer was pulled out of the sediment and a stopper was placed in the end to prevent a loss of sediment.

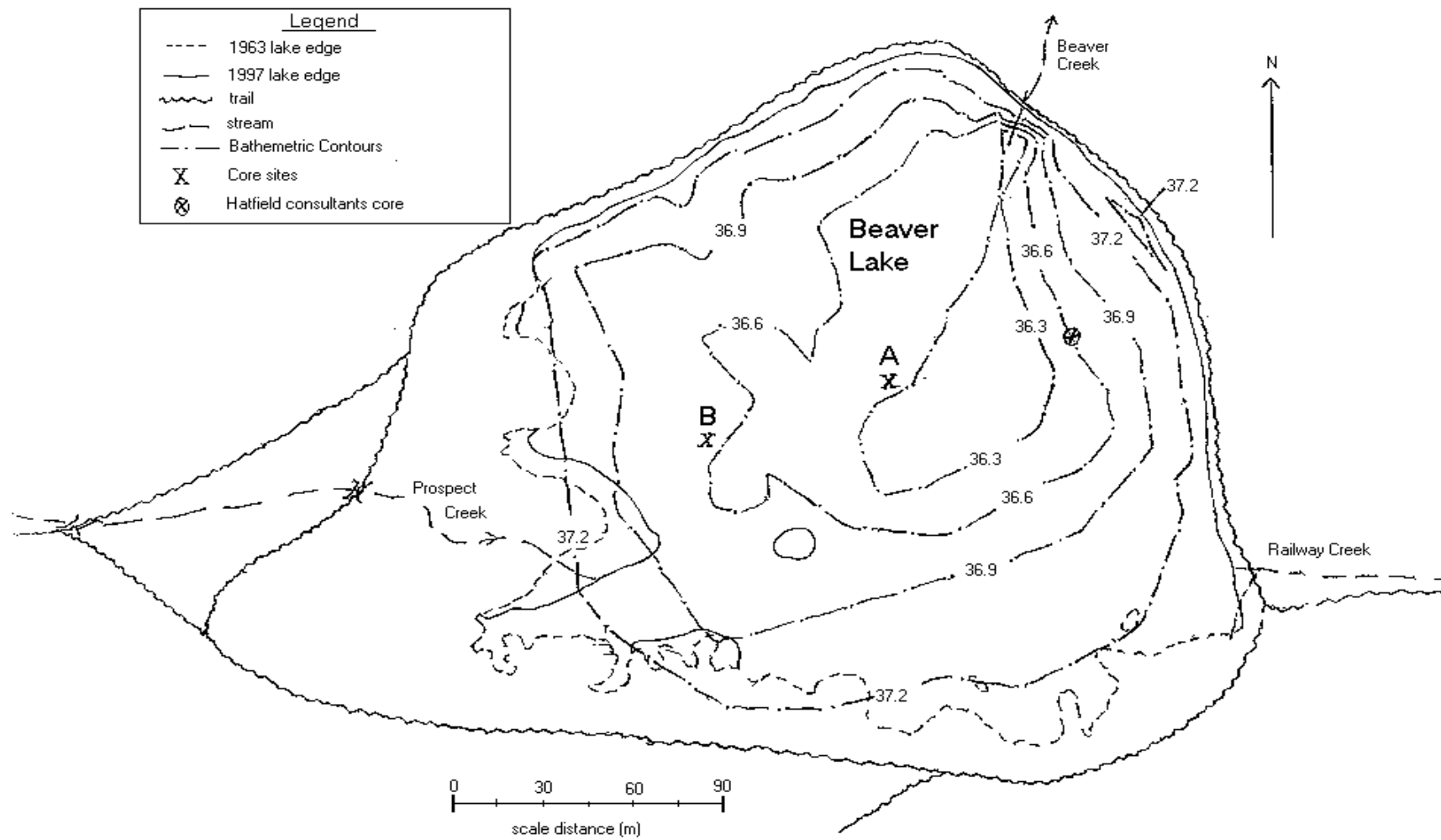

**Figure 6-2 Map of Corer sites**

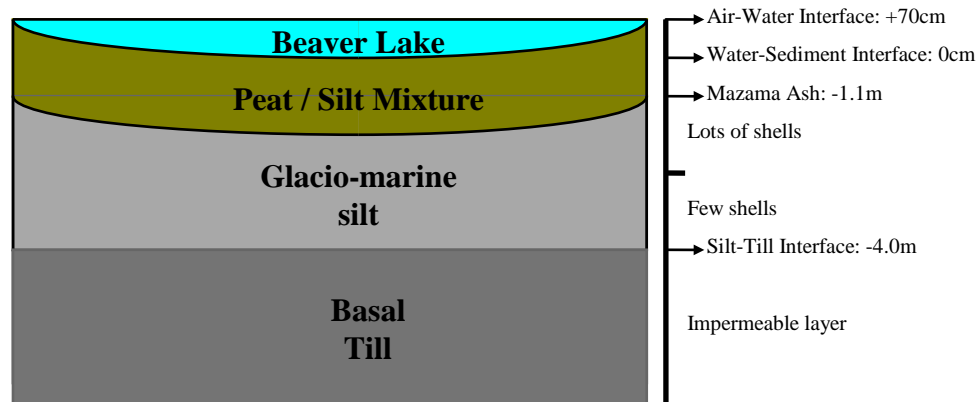

**Figure 6-3 schematic sediment profile of the lake**

### 6.1.2. Field description of cores

The Hiller cores were visible in the field and gave us some important results regarding the sediment profile (Figure 6-3). At site A the glacial marine silt was encountered about 1.1 meters below the sediment-water interface. The same silt was found to be 1 meter from the sediment-water interface at site B. This silt originates from when the park was under sea level and the silt settled out on the ocean floor. We managed to identify a few shell fragments in the silt. The silt was penetrable to a depth of 4 meters from the top of the sediment at site A. This would give the silt a depth of 3m. The material under the silt could not be brought up by the corer; but, it is probably the basal till which is common in the area.

### **6.2. Lab methods and results**

In determining which samples to select for analysis, we chose the least contaminated and the longest. This provided us with the most accurate representation of sediment characteristics throughout a long history of sedimentation. The cores which were chosen for detailed analysis were AL4 (site A, Livingston corer #4) and BL1 (site B, Livingston Corer #1). All the cores became highly compressed as part of the sampling. This is likely due to a number of factors. Firstly the sediment was not very dense and was easily compressible. Secondly, substantial gas bubbles were found in the sediment, especially at a depth of about 30cm below the sediment surface. The gas bubbles rose

out of the sediment when the corer was drawn up out of the water. Third, the sticky, silty nature of the sediment made it adhere to the core barrel sides and prevented it from sliding easily up the core barrel. AL4 compacted by a factor of 2.1 and BL1 compacted by a factor of 1.6. Ideally all the results would be presented with respect to their field lengths; however, we know that the compaction was not uniform throughout the depth of the core, and thus we would be misrepresenting the data by projecting the lengths back to the field lengths. This is a common problem with core samples, especially when the compaction factors are as large as ours are. For comparison, the core Hatfield Consultants (1984) took had a compaction factor of 1.3. All subsequent lengths throughout the report refer to the moist lengths measured after the initial compaction in the field had occurred.

#### 6.2.1. Visual description of cores

Physical descriptions of the cores were documented in their wet, dry and crushed state. Table 6-2 shows the physical descriptions for the cores when they were dry. (The appendix contains similar tables describing the cores in their wet and ground state.) These descriptions can be compared to Figure 6-4 through Figure 6-9 which are photos from the cores in their dry state. AL3 is included in this set as it shows up especially well in the photos. In all of the core descriptions 0cm is the top of the sediment.

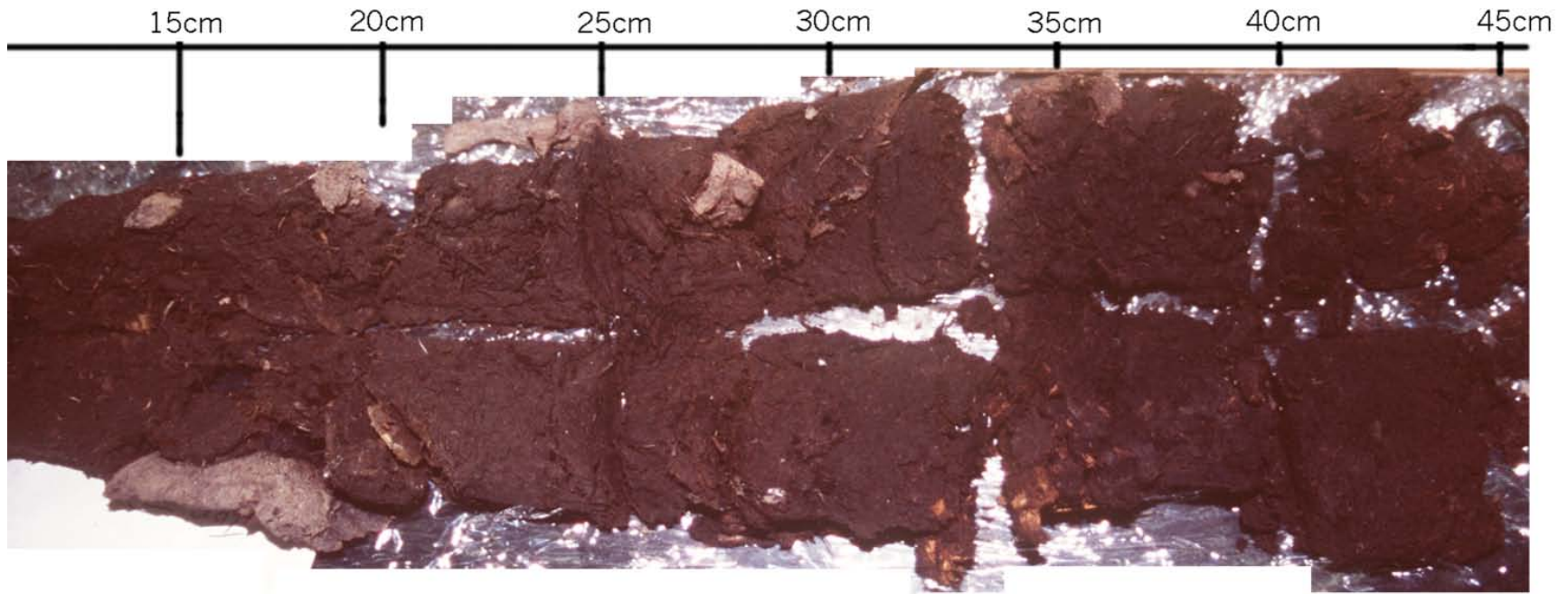

**Figure 6-4** Bottom section of the AL4 core

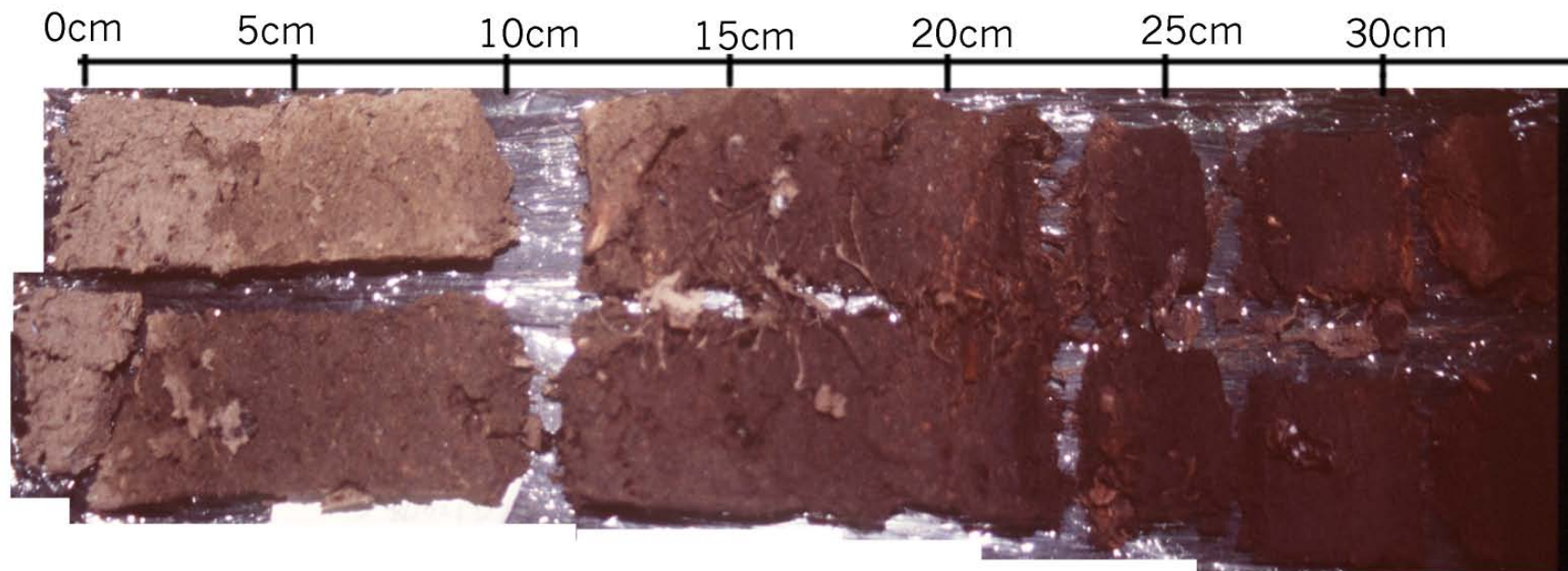

**Figure 6-5 Top section of the BL1 core**

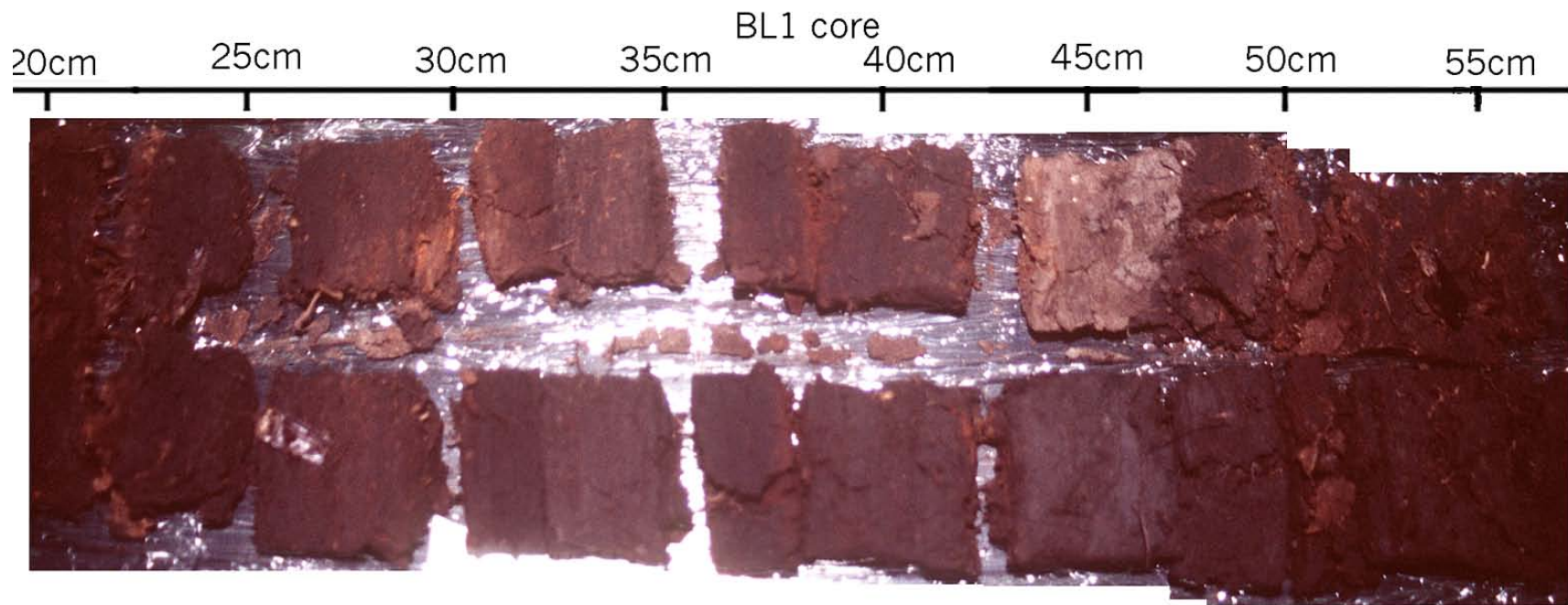

**Figure 6-6 Middle section of the BL1 core**

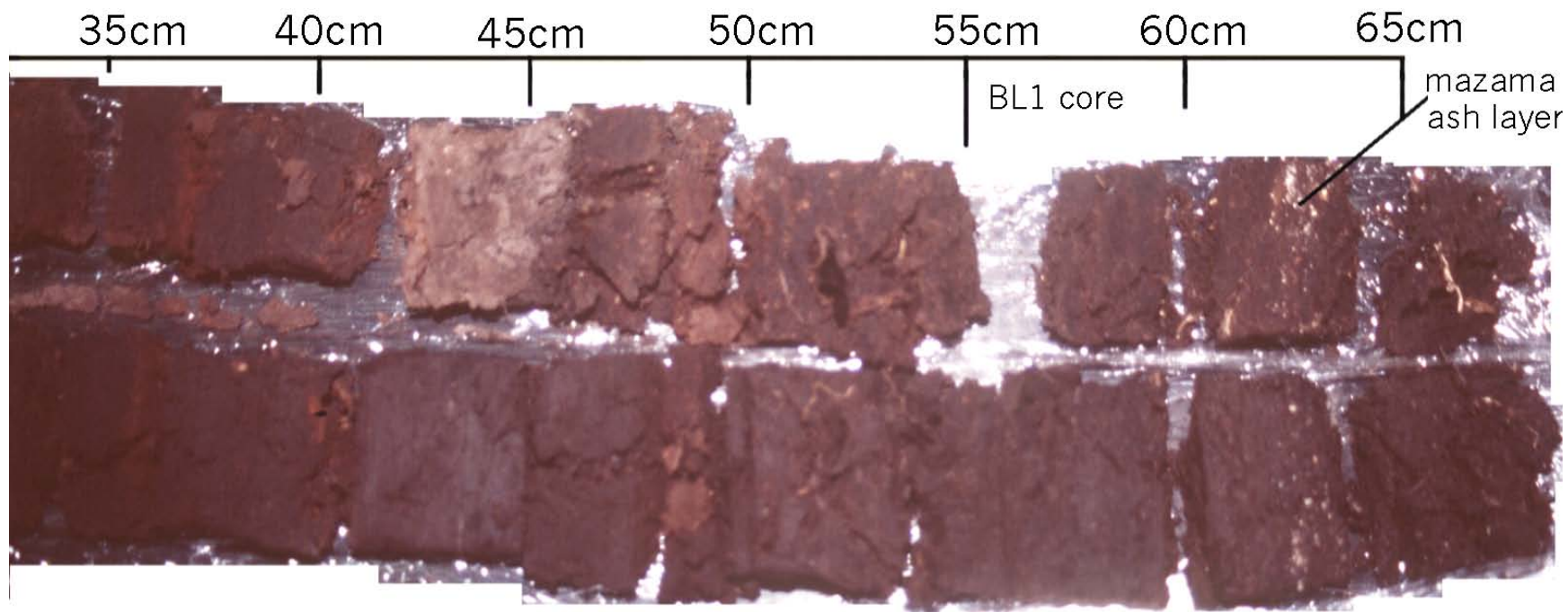

**Figure 6-7 Bottom section of the BL1 core**

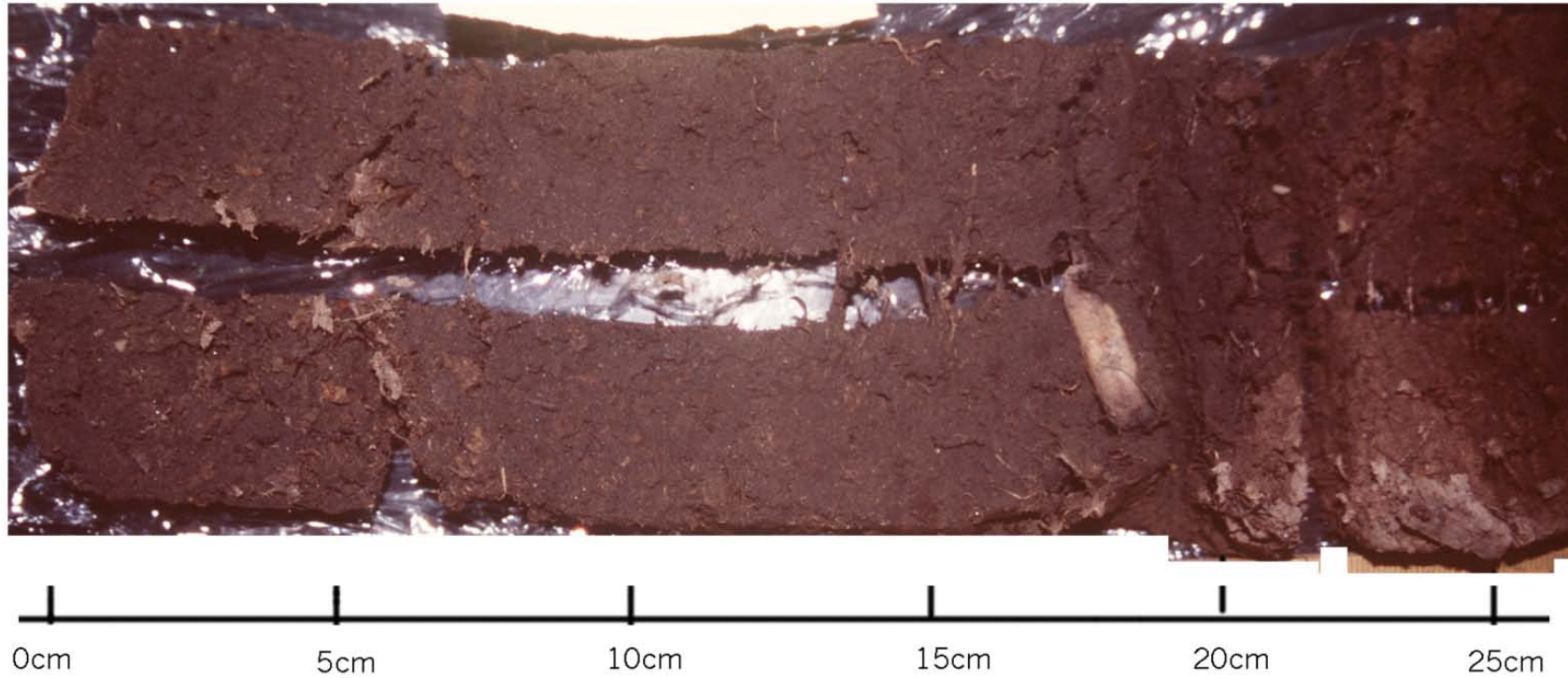

**Figure 6-8 Top section of the AL3 core**

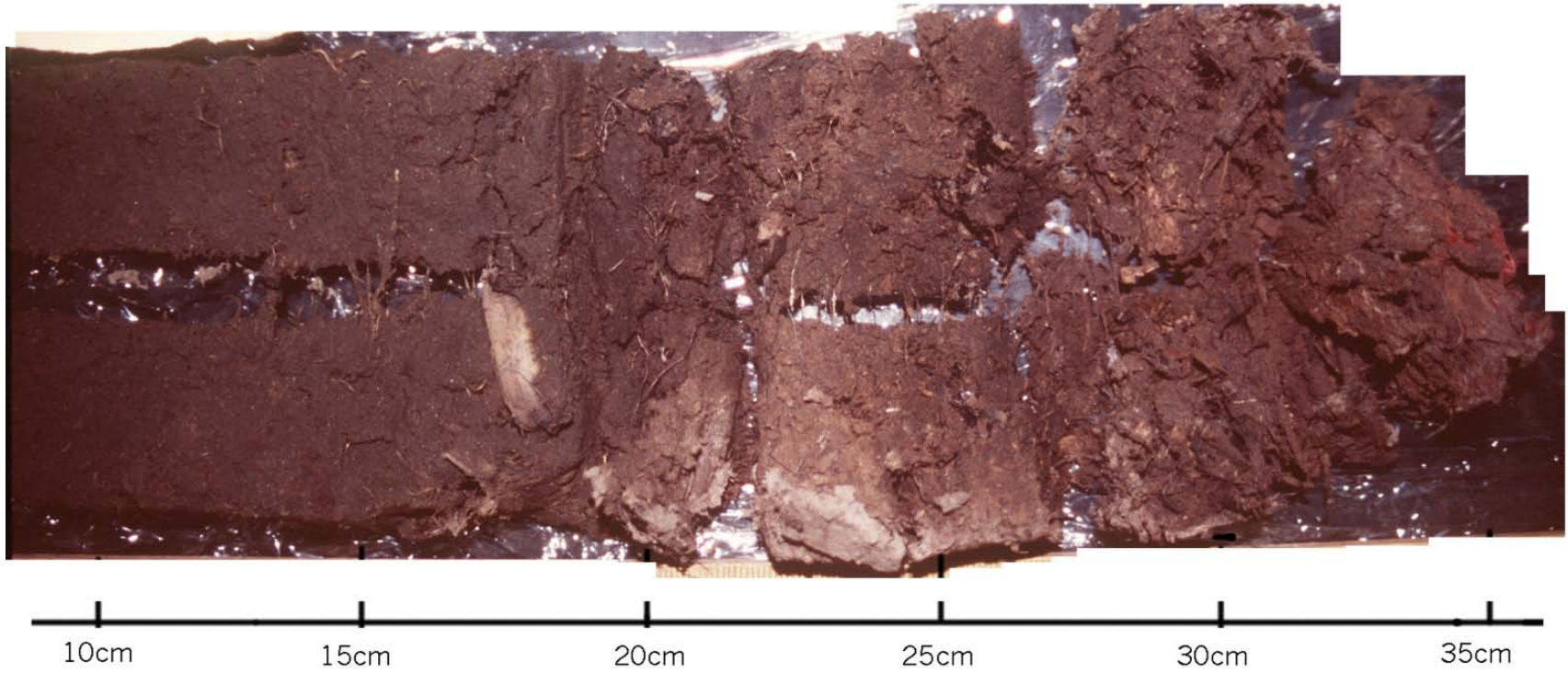

**Figure 6-9 Bottom section of the AL3 core**

**Table 6-2 Dry core descriptions for AL4 (top) and BL1 (bottom)**

Dry depth (mm)	Moist Depth (mm)	Description of AL4
0-96	0-156	light gray/brown; some fine veg.; some white specks on outside
96-169	156-275	more veg.; filamentous roots; large chunk of root; black inside (rubbery smell)
169-243	275-323	slightly paler; filamentous OM; bits of charcoal
243-291	323-355	more brown ; fewer filaments; large pieces of charcoal
291-311	355-372	woody root at top; more filaments
311-355	372-410	dark, almost black; white flecks at bottom
355-370	410-434	very dark; white flecks; fine and compact
370-395	434-475	suddenly slighter lighter with reddish tinge; long strip of charcoal; no more white flecks
Dry depth (mm)	Moist Depth (mm)	Description of BL1
0-90	0-115	grey/brown, fine veg.
90-118	115-154	more veg.
118-143	154-189	darker brown
143-161	189-214	lighter brown
161-171	214-235	darker brown
171-193	235-262	almost black
193-223	262-305	more brown shades
223-240	305-330	slightly darker; some black attached
240-260	330-365	more grey; darker

260-277 <sup>6*</sup> i)260-274 ii)274-277	365-388 i)365-384 ii)384-388	i)almost black ii)very thin reddish layer
277-307	388-343	dark with some grey further down
307-342	433-473	very grey
342-372	473-514	crumbly, reddish-brown
372-407	514-571	more reddish
407-432	571-608	black, fine sediment, little veg.
432-458	608-651	black with distinct layer of white specks (pebbles)
458-476	651-686	black with white specks

Following the visual descriptions the core samples were analyzed for heavy metals, carbon, nitrogen, percent organic and inorganic sediment sizing.

### 6.2.2. Mazama ash

In the photo of the bottom section of the BL1 core a distinct layer of organic material with white flocculated particles is evident. Similar specks were found in the bottom section of the AL4 core when it was ground up. The specks were exposed to hydrochloric acid and did not effervesce, indicating that the material was not shell fragments or carbonate in composition.

The material was concluded to be Mazama ash. Mazama ash is a widespread ash deposit from the eruption of Mt. Mazama 6600 yr. BP at what is now Crater Lake. The white specks were easily crushed, to break up the flocculated ash shards. When the shards were examined under a light microscope they appeared as glass shards and had small bubbles along the walls of the shards. This description fits the description given for Mazama ash by Reasoned and Healy (1986). It is unlikely that the ash is the Bridge River ash as this record is not known to have extended as far south as Vancouver. The Mazama

---

<sup>6</sup> This sample showed two distinct layers but was impossible to separate.

ash has been found in other areas of the Lower Mainland. No further tests were performed to confirm that the material was in fact the Mazama ash deposit.

### 6.2.3. Bulk density

As part of the analysis bulk densities were measured late in the analysis process, which resulted in some inaccuracies in the values of bulk density. In order to calculate the bulk densities the dry weights of half of each sample segment was measured and this was divided by the volume of space the segment occupied in the core barrel. This method resulted in error as the cores were cut in half by hand with no specific method to ensure the sample was evenly divided. Secondly the sediment was not transferred analytically and some sediment was undoubtedly lost before the samples were dried and weighed. The bulk densities likely have error margins of about 20 %, but are sure to fall within 50 % of the stated value. Figure 6-10 shows the vertical profiles of bulk density for the two cores.

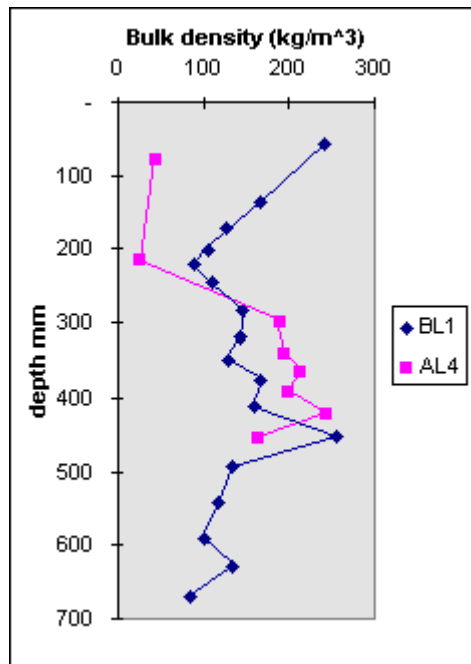

**Figure 6-10 Bulk density profiles for BL1 and AL4 core**

These bulk densities are very low compared to terrestrial soils. As a comparison, water has a density of 1000 kg/m<sup>3</sup> and inorganic sediment may have an average density around 2600 kg/m<sup>3</sup>. The exceptionally low densities indicate the degree to which the

material is unconsolidated and is simply suspended in the water column. This also indicates that it will take a lot more sediment to even make the existing sediment compact enough to support terrestrial vegetation.

#### 6.2.4. Total nitrogen

Nitrogen content was determined using the Total Kjeldahl Nitrogen Determination - Colourimetric by FIA Analyzer method (Lavkulich, 1998). The method involves the digestion of samples followed by analysis on a Lachat analyzer. Lachat analysis is a colourimetric technique used to determine total nitrogen present.

#### 6.2.5. Total carbon

Total carbon was determined using a LECO induction furnace and carbon analyzer which involves the combustion of the sample, followed by reaction with KOH to remove the CO<sub>2</sub> and give a reading of total carbon (Lavkulich, 1998).

#### 6.2.6. Percent organic

Samples were dried at 125 for 24hrs. to remove all water. The samples were weighed and were subsequently burned at 550 degrees C for five hours and then placed in a digester to cool and then re-weighed. The difference in masses, or loss on ignition, gives the loss of organic material.

As more samples were burned than were analysed with the LECO machine it was necessary to determine the amount of carbon for some of the samples based on the loss on ignition (LOI) values. A regression analysis was performed in order to determine percent carbon values from the LOI burns. Percent carbon values were plotted against percent organic and a linear trend line was fitted to the plot. The R<sup>2</sup> value for this relationship is equal to 0.988. We are therefore confident that values for percent carbon calculated using the relationship are accurate. Figure 6-11 shows the relation and gives the best fit equation for the plotted straight line.

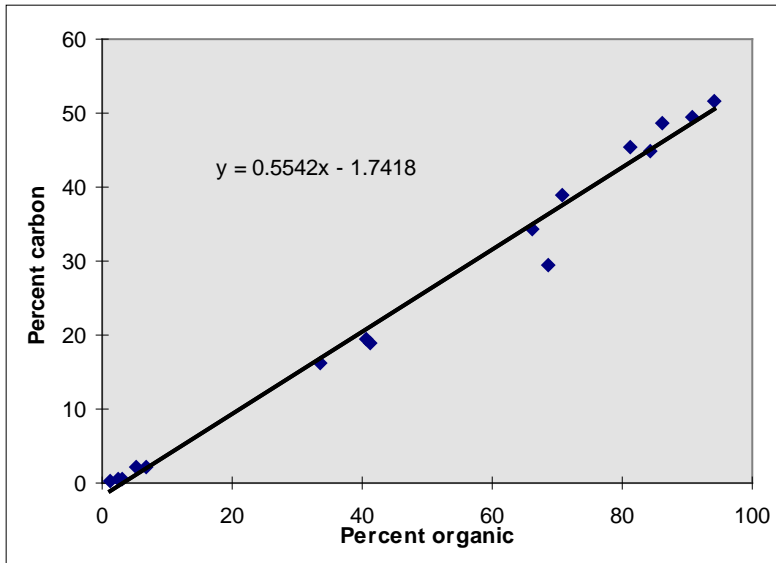

**Figure 6-11 Linear trend for percent carbon vs. percent organic**

### 6.2.7. Carbon to nitrogen ratios

The issue of organic matter in Beaver Lake is important, as it has generally been the deposition of organic matter that has been thought to be causing much of the sedimentation in the lake. While measurement of total organic matter gives a good idea of what is present, we were interested more specifically in the ration between total carbon and total nitrogen. C/N ratios provide a good indication of what is going on in the sediment in terms of mineralization or immobilization of organic matter. During decomposition, C is lost as CO<sub>2</sub> while N remains so that during decomposition, the C/N ratio of the sediment drops. With a high C/N ratio, most of the mineralized N is re-immobilized into forms unavailable for assimilation by plants. When the C/N ratio is low (i.e. high N concentration) decomposers will mineralize more N than is re-immobilized, resulting in a lot of plant-available nitrogen (Ballard 1997). The C:N ratio in the sediment in the sediment is dependent on the amount of structure found in the source vegetation, for example tree trunks have a much higher C: N ratio than tree leaves. This is because there is more carbon found in the strong cell walls of the wood. Aquatic macrophytes often have even lower C:N ratio values than terrestrial leaves. If the primary sediment source is terrestrial wood and leaves the C:N ratio found in the sediment will be higher than that found if the primary source is aquatic macrophytes. For all of our

vertical profiles the sample points are plotted as the depth of the mid point of the core segment from which the sample was taken.

### AL4 cores

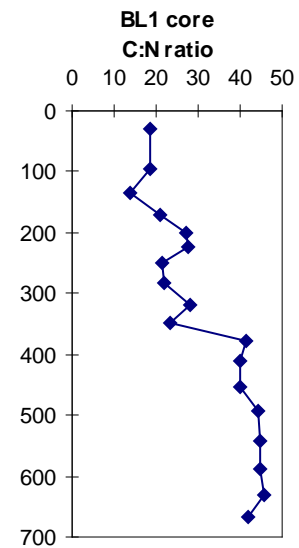
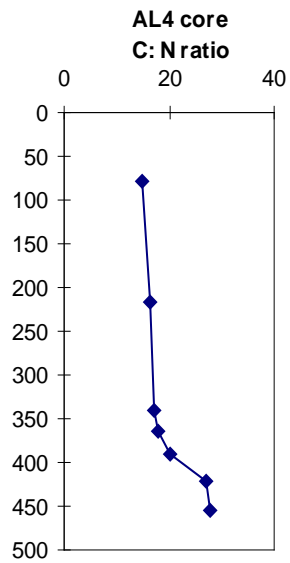
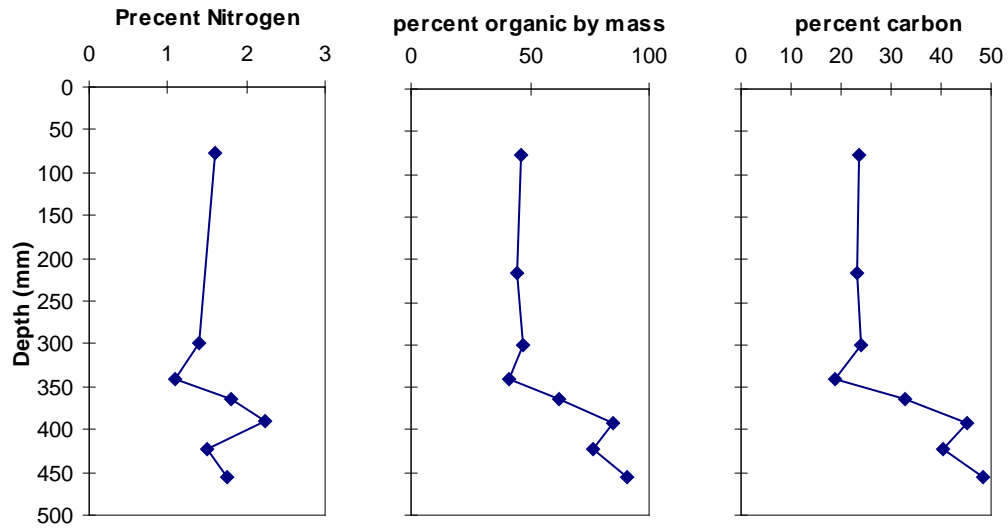

### BL1 cores

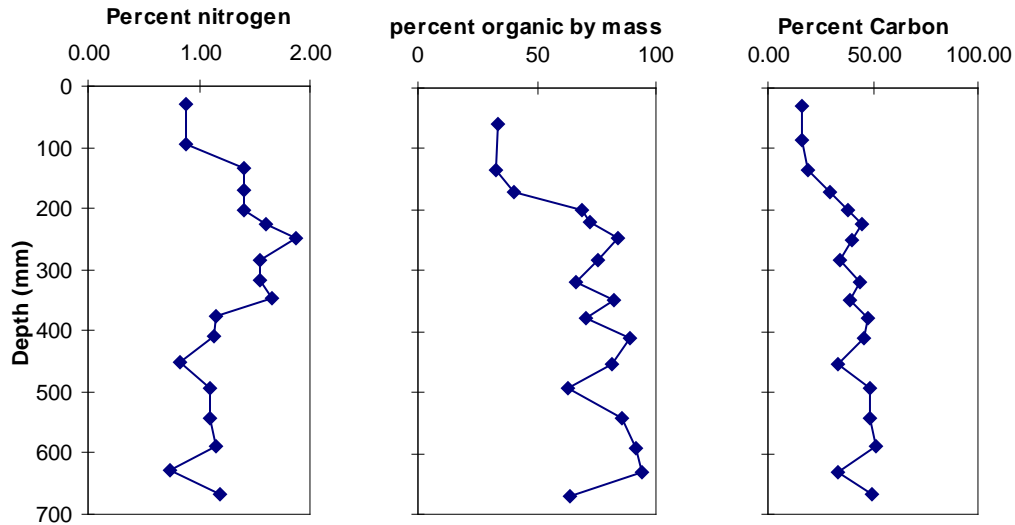
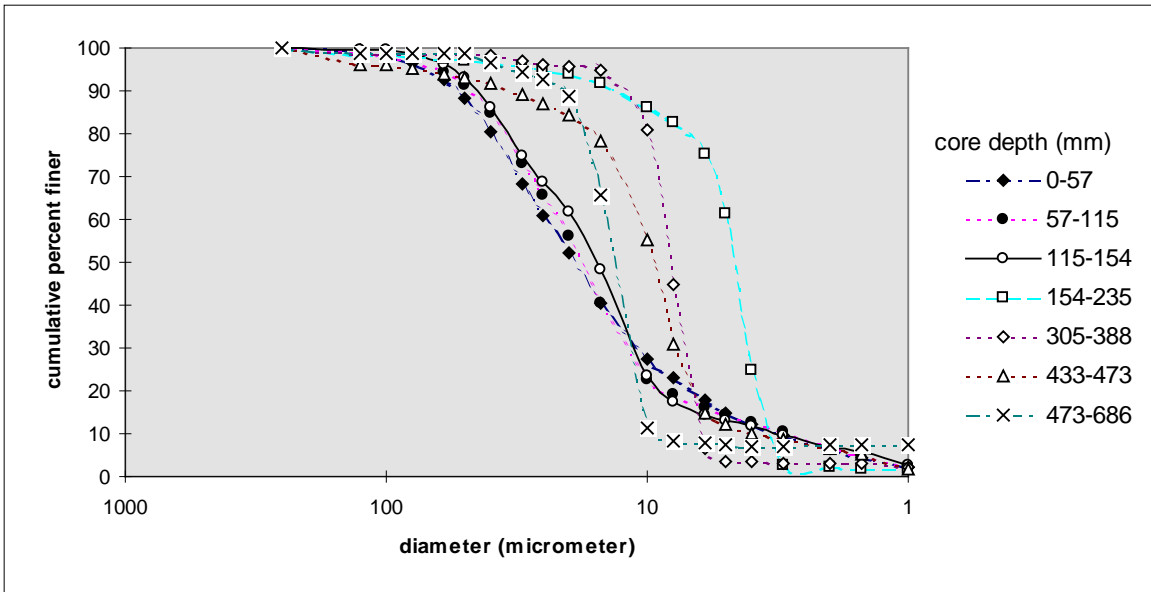

**Figure 6-12 Nitrogen, carbon, organic, and C:N ratio profiles**

#### 6.2.8. Mineral size fraction

In an effort to determine the source and composition of the mineral portion of the sediment a sediment size analysis was performed. LOI was performed and then the burned samples were sieved to 250 micrometers?, weighed, sieved to 125, weighed, and the remaining sample was analyzed in a sedigraph machine. The sedigraph measures the settling velocity of the particles by means of an x-ray tube and measures the representative size fraction of particles as small as 1 micron.

Figure 8-4 and 8-5 show the plots of the cumulative percent finer than vs. particle size for the two sample sites. These plots show the percentage of the sample which is finer than a given size/diameter.



**Figure 6-13 BL1 cumulative percent finer than**

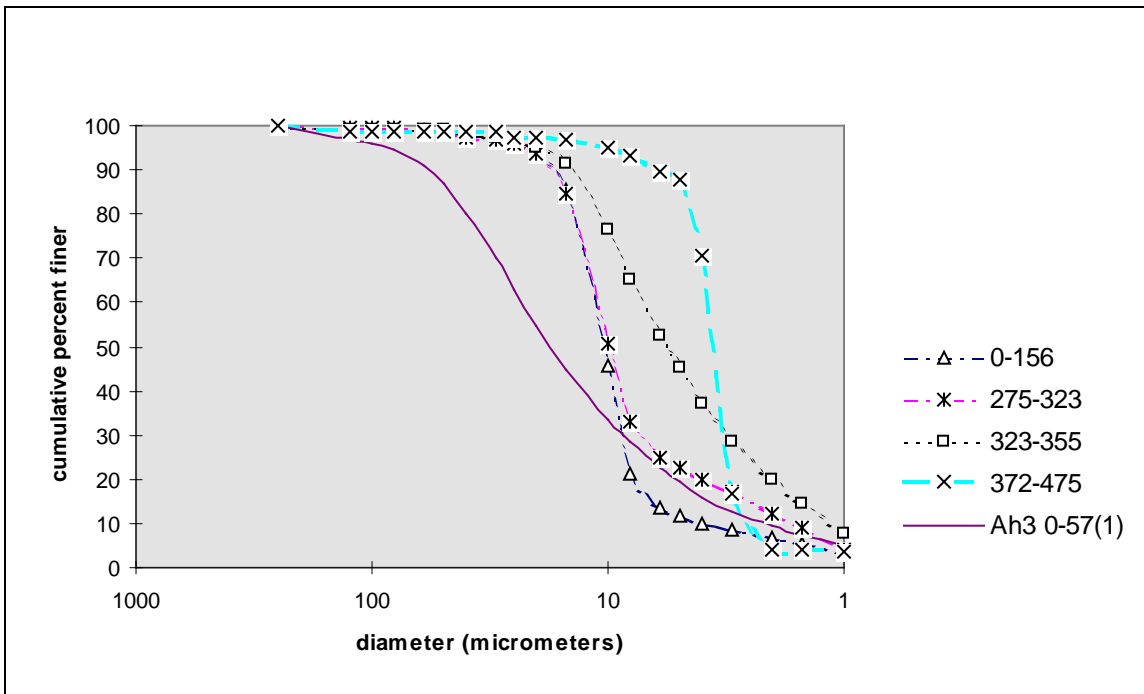

**Figure 6-14 AL4 and AH3 cumulative percent finer than**

From the above figures we can see site A is noticeably finer than site B, we also see that the top three samples from site B are coarser than the underlying sediments. These samples are most definitely from the post industrial time period. The inorganic

sediments at site B appear to have become finer with time in the pre-industrial period. Why this would happen is not known. When we look at Table 6-3 we see that the size of the material can have a major effect on the time it takes for particles to settle out. This means the sediment becomes finer further away from the sediment sources because the sediment is in the water for an increasingly long period of time. The finer sediment size in core AL4 as compared to BL1 is likely due to this phenomenon. If the inorganic sediment was added to the lake by wind transport we would not expect to see a gradation in the sediment sizes across the lake. The observed trend indicates that the sediment is likely coming in from the lake edge; however, we cannot determine if it is from Prospect creek directly, or simply the lake margin.

**Table 6-3 Settling velocities based on stokes law for silt particles**

grain size	15 microns	10 microns	6 microns
settling velocity	0.00015m/s	0.000067 m/s	0.000024
time to settle (70cm)	1.30 hours	2.90 hours	8.1 Hours

The median grain size for the top section of the BL1 core is 18.92 microns and for the AL4 core the median size is 10.29 microns. When comparing these values with the settling times in Table 6-3 we get reasonable mixing times for the lakes. Using these settling times, the travel times for the water to reach sites A and B from the margin of the lake are approximately three hours and one hour, respectively. These seem like reasonable estimates, keeping in mind that the majority of the silt is transported into the lake during heavy rainstorms.

### 6.2.9. Metals

In addition to analysing for the characteristics mentioned above, the concentrations of a number of metals were measured. High metal concentrations are indicative of industrial human activity and we have used the increases in metal concentrations to estimate sedimentation rates. By correlating our data with data from Burnaby Lake we were able to use changes in metal concentrations, specifically heavy metal concentrations, to estimate sedimentation rates. Radiometric dating of the Burnaby

Lake sample established correlations between concentrations of these metals in the sediment and human activity (Hall ).

### **6.2.9.1.Sources of heavy metals**

Metals, elements defined based on their binding affinities towards ligands and the stability of these ion/ligand complexes, occur naturally in both the biosphere and the geosphere. The term “heavy metal” is generally applied to those metals with a density exceeding  $5\text{g/cm}^3$ . In present day watersheds natural sources of heavy metals are greatly outweighed by anthropogenic sources. These anthropogenic sources include emissions from three sources: point sources, area sources and mobile sources. Point sources are the largest contributors to particulate pollution in the atmosphere. Emissions from metal fabrication, petroleum refining, chemical manufacturing and municipal waste incineration account for most of the point source emissions of heavy metals. Historically, space heating was a major source contributor in the area. In the last 30 years however, we have seen a shift to cleaner, more efficient space heating methods. Lastly, vehicle emissions account for most of the mobile source heavy metal emissions and constitute a large portion of the total heavy metals emitted in the Fraser Valley (Pott 1995).

In the Fraser Valley, a study using the moss *Isoetecium stoloniferum* Brid. as a bioindicator of atmospheric heavy metals found that, in general, concentrations of Pb, Cd, Ni, Zn, and to an extent Cr and Mn, were generally high in areas of high industrial activity, high population density, and high traffic volume (Pott, 1995). High levels also existed in the North Shore mountains, probably a result of both a north-west directed transport as well as high precipitation at high altitudes. In a comparison with data from 1960-66, 1975-80, and 1993, Pb, Cd, Cr, Ni, Zn showed a decrease, while Mn showed an increase since the 1960s. Reasons for these changes are mainly attributed to changes in anthropogenic activities such as changes in industrial activity, implementation of pollution control devices, a switch to gas and electricity in space heating devices, and the removal of lead from gasoline, coupled with the introduction of the new MMT (Mn) additive (Pott 1995).

### **6.2.9.2. Analysis for metals**

Analyses were done for: Al, Ca, Cd, Cr, Cu, Fe, Mg, Mn, Pb, Si, Zn, K, Na. Samples were extracted for analysis using a procedure for total recoverable elements from the Environmental Monitoring Systems Laboratory of the U.S. Environmental Protection Agency (C.K. Smoley, 1992). Samples were then analyzed using ICP (Inductively coupled plasma atomic emission spectrometry), a procedure in which the interaction of a magnetic field with flowing ionized gas generates what is known as the ICP flame. The ICP vaporizes, dissociates, atomizes and excites the sample. Photons are emitted in energy transfer reactions and these promote atomic and ionic line spectra, which allow for a reading of metal concentrations in ppm (Lavkulich, personal communications).

### **6.2.9.3. Metal profiles**

The concentration of heavy metals is confounded by the presence of organic material which fluctuates in amount throughout the core profile (Figure 6-12). As a result of this complication the metals have been re-plotted as metals normalized for carbon to eliminate the effects of organic matter. Figure 6-15 and Figure 6-16 cleaner than the non-normalized set of figures which are contained in the appendix. Both sets of profiles have strong indications of industrialization with marked increases in the concentration of almost all of the heavy metals.

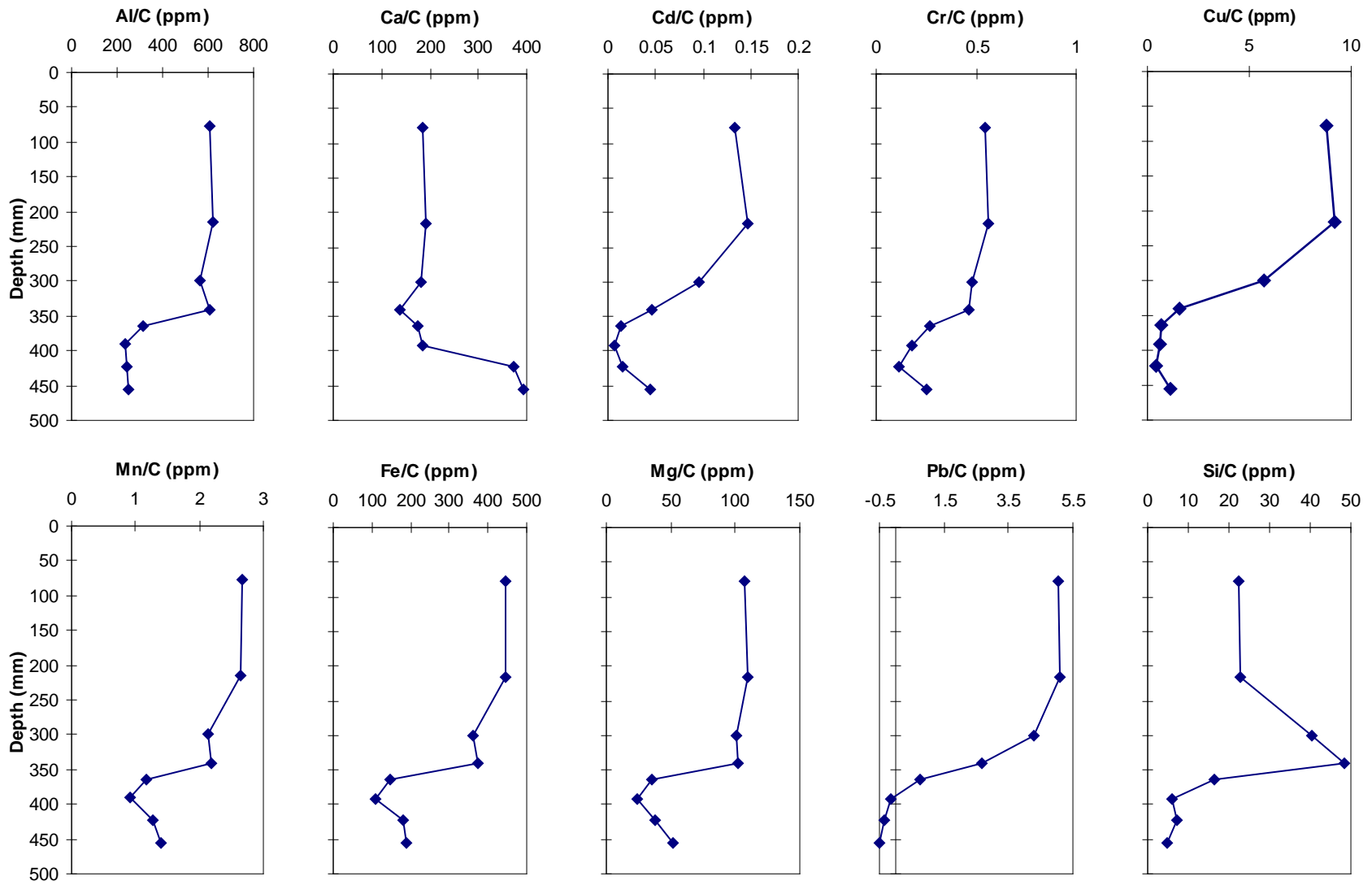

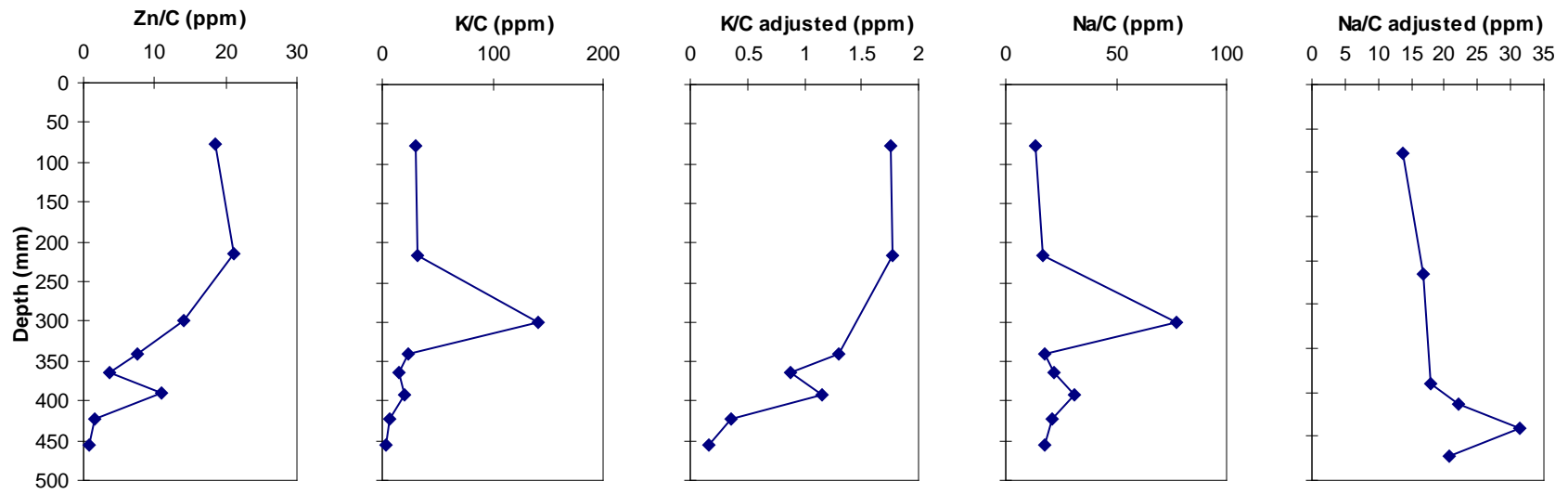

**Figure 6-15 AL4 heavy metal profiles normalized for carbon**

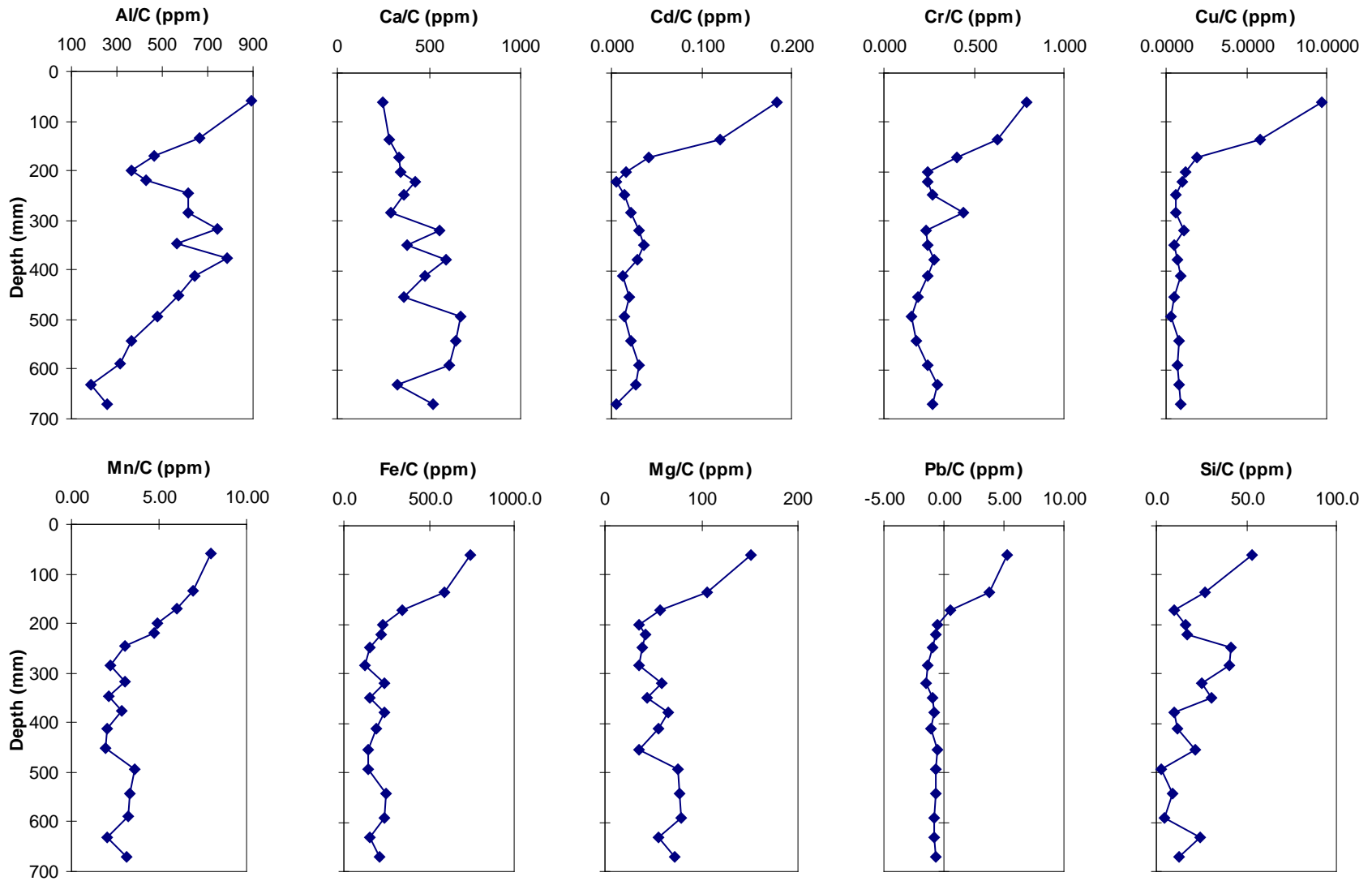

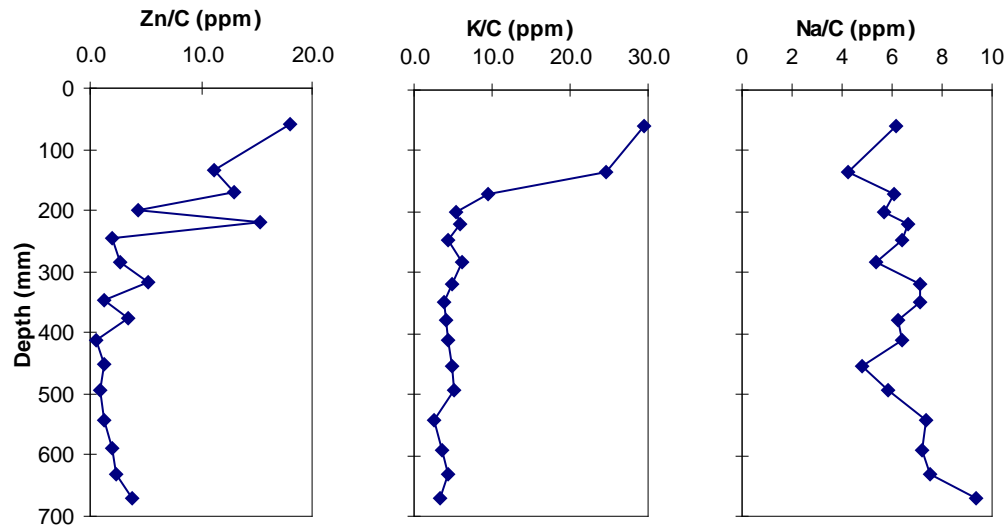

**Figure 6-16 BL1 metal profiles normalized for carbon**

#### **6.2.9.4. Correlation tables**

In detail we have the following observations regarding the AL4 core: At 391mm, we do not see any increases in metal concentrations. At 364mm, Al, Mn, Fe, Mg, Pb, Si, Cr are just beginning to show an increase with depth. At a depth of 340mm, Cd, K, and Cu begin to increase as well. This difference is useful in subsequently developing sedimentation rates. For both Na and K we see anomalously high values at a depth of 300mm. This is likely a result of experimental error and the adjacent plots are shown with the outlying point removed.

In the BL1 core profiles the record of humans is much shorter, and the pre-industrialized record is very stable. At 201mm, all metals are still showing background levels except Mn which is slightly elevated. At 171mm, all metals are beginning to increase

except Cu, Si, and Na, and at 135mm these are increasing as well. It is interesting to note that metal concentrations are still increasing at the top of the core. This may be an indication of slower recent sedimentation rates, or an indicator that the basin has yet to become adjusted to somewhat lower levels of particular heavy metals such as lead. Another possible reason is our sample spacing was not sufficiently frequent for the trend to show up.

In order to see what is related, or what might be coming from the same source we calculated correlation values for both cores. We also constructed correlation tables for the metals normalized by carbon. Table 6-4 to Table 6-7 show the results of these correlation calculations. Grey highlights values of  $r > 0.90$  or  $r < -0.90$ . We see that the metals normalized for carbon are more frequently correlated with each other. We also see that nearly every metal is correlated with all the other metals. The noticeable exception to this trend is Calcium, which is not correlated with any of the heavy metals. This indicates that Calcium concentrations have not been influenced by humans, or at least not in the same way as the other metals. Industrialization shows up as one big source and individual sources such as heavy industry and the automobile are indiscernible, based on the wide spread correlations.

Table 6-4 Correlation values for the AL4 core

Al4	Al (ppm)	Ca (ppm)	Cd (ppm)	Cr (ppm)	Cu (ppm)	Fe (ppm)	Mg (ppm)	Mn (ppm)	Pb (ppm)	Si (ppm)	Zn (ppm)	K (ppm)	Na (ppm)	N (%)	C (%)	C:N
Al	1.00															
Ca	-0.64	1.00														
Cd	0.82	-0.29	1.00													
Cr	0.97	-0.60	0.89	1.00												
Cu	0.79	-0.36	0.98	0.86	1.00											
Fe	0.96	-0.42	0.91	0.95	0.87	1.00										
Mg	0.97	-0.44	0.87	0.95	0.81	0.99	1.00									
Mn	0.95	-0.40	0.93	0.95	0.89	1.00	0.98	1.00								
Pb	0.95	-0.60	0.92	0.96	0.92	0.94	0.92	0.94	1.00							
Si	0.82	-0.66	0.39	0.72	0.34	0.68	0.76	0.64	0.66	1.00						
Zn	0.76	-0.61	0.85	0.80	0.91	0.76	0.71	0.76	0.88	0.38	1.00					
K	0.47	-0.37	0.39	0.46	0.40	0.39	0.47	0.37	0.54	0.58	0.43	1.00				
Na	0.13	-0.21	0.06	0.12	0.08	0.04	0.13	0.00	0.20	0.37	0.16	0.93	1.00			
N	-0.69	0.12	-0.39	-0.56	-0.26	-0.71	-0.74	-0.67	-0.51	-0.78	-0.03	-0.30	-0.10	1.00		
C	-0.94	0.72	-0.61	-0.86	-0.59	-0.84	-0.84	-0.81	-0.87	-0.92	-0.58	-0.51	-0.25	0.73	1.00	
C:N	-0.78	0.94	-0.54	-0.78	-0.63	-0.61	-0.60	-0.61	-0.82	-0.68	-0.81	-0.49	-0.28	0.21	0.82	1.00

**Table 6-5 Correlation values for the BL1 core**

BL1	Al (ppm)	Ca (ppm)	Cd (ppm)	Cr (ppm)	Cu (ppm)	Fe (ppm)	Mg (ppm)	Mn (ppm)	Pb (ppm)	Si (ppm)	Zn (ppm)	K (ppm)	Na (ppm)	N (ppm)	C (%)	C:N
Al	1.00															
Ca	-0.21	1.00														
Cd	0.55	-0.47	1.00													
Cr	0.49	-0.65	0.91	1.00												
Cu	0.50	-0.49	0.97	0.92	1.00											
Fe	0.46	-0.38	0.94	0.88	0.97	1.00										
Mg	0.33	-0.01	0.85	0.71	0.97	0.87	1.00									
Mn	0.27	-0.37	0.77	0.76	0.84	0.89	0.69	1.00								
Pb	0.43	-0.48	0.95	0.89	0.97	0.96	0.84	0.87	1.00							
Si	0.52	-0.73	0.57	0.64	0.55	0.38	0.21	0.24	0.45	1.00						
Zn	0.30	-0.46	0.66	0.72	0.74	0.77	0.52	0.86	0.73	0.33	1.00					
K	0.52	-0.55	0.96	0.94	0.97	0.95	0.79	0.85	0.98	0.54	0.74	1.00				
Na	-0.49	0.43	-0.33	-0.34	-0.29	-0.26	0.00	-0.31	-0.36	-0.23	-0.19	-0.44	1.00			
N	0.17	-0.13	-0.22	-0.06	-0.20	-0.17	-0.42	0.02	-0.24	0.22	0.08	-0.14	-0.07	1.00		
C	-0.41	0.86	-0.79	-0.84	-0.78	-0.71	-0.42	-0.63	-0.79	-0.68	-0.60	-0.84	0.55	0.12	1.00	
C:N	-0.51	0.72	-0.54	-0.67	-0.55	-0.52	-0.13	-0.60	-0.52	-0.68	-0.61	-0.62	0.46	-0.59	0.71	1.00

**Table 6-6 Correlation values for Al4 normalized for carbon**

Al4	Al (ppm)	Ca (ppm)	Cd (ppm)	Cr (ppm)	Cu (ppm)	Fe (ppm)	Mg (ppm)	Mn (ppm)	Pb (ppm)	Si (ppm)	Zn (ppm)	K (ppm)	Na (ppm)
Al	1.00												
Ca	0.29	1.00											
	0.80	0.41	1.00										
Cr	0.99	0.28	0.87	1.00									
Cu	0.72	0.35	0.99	0.80	1.00								
Fe	0.98	0.39	0.88	0.99	0.81	1.00							
Mg	0.99	0.37	0.83	0.99	0.75	0.99	1.00						
Mn	0.98	0.38	0.88	0.99	0.81	1.00	0.99	1.00					
Pb	0.92	0.31	0.96	0.96	0.93	0.95	0.93	0.96	1.00				
Si	0.89	0.17	0.46	0.82	0.34	0.80	0.86	0.80	0.67	1.00			
Zn	0.81	0.19	0.96	0.87	0.96	0.86	0.82	0.86	0.95	0.48	1.00		
K	0.48	0.11	0.45	0.50	0.44	0.45	0.50	0.44	0.56	0.54	0.47	1.00	
Na	0.35	0.02	0.27	0.35	0.25	0.30	0.36	0.29	0.40	0.50	0.30	0.98	1.00

**Table 6-7 Correlation values for the BL1 core normalized for carbon**

BL1	Al (ppm)	Ca (ppm)	Cd (ppm)	Cr (ppm)	Cu (ppm)	Fe (ppm)	Mg (ppm)	Mn (ppm)	Pb (ppm)	Si (ppm)	Zn (ppm)	K (ppm)	Na (ppm)
Al	1.00												
Ca	0.58	1.00											
Cd	0.94	0.65	1.00										
Cr	0.94	0.56	0.98	1.00									
Cu	0.94	0.64	1.00	0.98	1.00								
Fe	0.93	0.66	0.99	0.98	0.99	1.00							
Mg	0.91	0.70	0.99	0.97	0.99	0.98	1.00						
Mn	0.89	0.62	0.96	0.96	0.96	0.98	0.95	1.00					
Pb	0.92	0.68	0.99	0.97	0.99	0.99	0.99	0.97	1.00				
Si	0.91	0.34	0.90	0.91	0.90	0.86	0.86	0.81	0.85	1.00			
Zn	0.87	0.55	0.93	0.94	0.94	0.95	0.92	0.97	0.93	0.82	1.00		
K	0.94	0.64	0.99	0.99	0.99	0.99	0.98	0.98	0.99	0.88	0.93	1.00	
Na	0.79	0.43	0.89	0.89	0.89	0.87	0.89	0.84	0.86	0.88	0.87	0.86	1.00

### **6.3. Discussion of sediments**

The data and graphs normalized by percent carbon show more distinct trends than those not normalized and are therefore referred to in the subsequent discussion. From the graphs, we suspect the effects of the introduction of humans into the system. Pb, Cd, Zn, Cr (elements associated with anthropogenic inputs of atmospheric heavy metals) all show a marked increase at approximately the same depth.

Both BL1 and AL4 show an episodic increase in zinc concentration before the trend strongly increases. This may be from a particular event before major changes in metal concentrations are detected; this trend also shows up in a core from Burnaby lake (McCallum and Hall 1998). The presence of the spike in both of our cores as well as in the core from Burnaby lake indicates that there was likely an episodic event during which zinc was released into the environment.

We see no decrease in any of our metal concentrations. However, there have been emission reductions and pollution control over the last 30-40 years which should reduce the levels of metals in the lake. Based on the experiences at Burnaby lake (McCallum and Hall 1998) we expect the lead concentration to decrease in the recent sediments as lead has been removed from gasoline.

We may not be able to detect the decreases for a number of reasons. First of all, our samples were collected from 5-10 cm lengths of core. This means the metal data points are not on a small enough scale to be able to track decreases in concentration over the length of the sample. Secondly, the sediment may be getting sufficiently mixed, by the carp in the lake in particular, so that the metals do not appear to decrease in concentration. A third possibility is that the metals are taking sufficiently long to make their way through the forest soils and into the lake that the input of metals has not noticeably decreased for Beaver Lake. This last point makes the determination of sedimentation rates challenging as we are assuming the metals begin to arrive in the lake when they are first introduced into the environment.

### 6.3.1. Chemical availability

The chemical forms of metals influence their bioavailability, stability, and capacity for remobilization. Dissolved or weakly adsorbed metals may be available to plants, while others bound in the structural lattices of secondary minerals will be extremely stable and unavailable. In between, there lie many different forms which can potentially become available depending on physio-chemical conditions. The main sediment properties governing potential for remobilization include gradients of redox conditions, pH, and ion and organic ligand concentrations. When sediments are resuspended, the potential for release of metals exists and mobilization depends on both how the metals are bound as well as acid production and acid neutralization capacity in the process. In general metal availability becomes a concern when the metals are re-suspended. Thus, re-suspension should be avoided (Munawar and Dave 1996).

### 6.3.2. Sedimentation rates in Beaver Lake

The most precise method of determining sedimentation rates in systems like Beaver Lake is by using radiometric dating techniques. Hatfield Consultants (1984) estimated a sedimentation rate of 1.36 cm/yr. based on a single core, and pollen analysis. Based on a conversation with Rolf Matthews from SFU who did the pollen work on this core this estimation of sedimentation rate is unreliable (personal communications, Rolf Matthews). We concluded that the core taken by Hatfield consultants likely came from the previously dredged<sup>7</sup> portion of the lake. This would bias the sedimentation rate. Hatfield consultants was advised by Dr. Matthews to obtain a radiometric date for the core but did not do so. The radiometric date would be necessary to give a good sedimentation rate based on Hatfield consultant's core.

For our purposes a second sedimentation rate estimate was deemed to be beneficial, and like Hatfield we do not have a radiometric date for our core.<sup>8</sup> However, we have a higher degree of certainty with respect to our sedimentation rate than that

---

<sup>7</sup> The lake is reported to have been dredged in 1929 and 105,505 m<sup>3</sup> were removed (Steele 1985), this must be a mist print because this is would require all of the glacial marine silt to be removed from the basin as this volume is 4 times the current lake volume.

<sup>8</sup> We still have samples which could be dated, cheap cesium dating is about \$50.00 a sample, 3-4 samples per core would likely give excellent results, contact one of us if interested.

which can be expected from the Hatfield Consultants core. The presence of the Mazama ash at the bottom of both of our cores indicates that the sediment history is intact and that the site was almost certainly not affected by the original dredge in 1929 (Stanley Park Task Force 1992).

We were able to calculate sedimentation rates for both the period since the Mazama ash deposit (6600yrs BP) and for the post industrialization period. When calculating sedimentation rates it is best to represent the values on a weight basis as this eliminates the problems resulting from variable densities in the sediment profile. Giving only lengths is ambiguous as sediments, especially aquatic sediments, can have variable densities and are compressed over time.

The sedimentation rates were calculated by a variety of means and all cover a slightly different time span. All of the sedimentation rates have been calculated up to present day since the date the particular signature metal shows up in the system. This means that the Mazama ash sedimentation rate includes all of the sedimentation since human impact in the basin. The Mazama ash was identified in both cores and forms our only pre-industrial sedimentation rate.

The oldest recorded date associated with humans comes from the perceived impact of selective logging in the 1860-1880's (Beese 1989). This would be expected to increase the inorganic sediment supply and increase some of the metal concentrations. None of the increases observed in the core profiles can be directly attributed to the logging. However, it is useful to tie this date to the first noticeable increase in the records to construct a minimum sedimentation rate.

The profile of zinc in our cores provides the most reliable sedimentation rate for the recent period of human involvement. As was mentioned earlier there is a spike in the zinc concentration in both the A14 and B11 cores. A similar spike shows up in the Burnaby Lake core (McCallum and Hall, 1997). We believe these three spikes to represent the same time period and have used the dates supplied by McCallum and Hall (1997) to date these spikes. The sedimentation rates are shown in the table below.

McCallum and Hall (1997) also examined lead, and from their profiles it is possible to assign a date to the major increase in the lead concentration. We subsequently

assigned this date to a similar, major increase in the lead concentration in order to date our cores.

In both our results and McCallum and Hall (1997) a lag can be observed in the onset of the increase in the copper concentrations. As the increase in the copper shows up later in both lakes it may represent the same increase in the supply of copper to the environment. Based on this we assigned the date of the copper increase detected in Burnaby Lake to the increase in the concentration of copper in our results.

**Table 6-8 Sedimentation rates for Beaver Lake**

Method	Date	A14 core (mm/yr.)	A14 core (kg/m <sup>2</sup> /yr)	B11 core (mm/yr.)	B11 core (kg/m <sup>2</sup> /yr)	sediment input based on average sedimentation rate (kg/yr.)
Mazama ash <sup>9</sup>	6600 Yrs. BP	0.072 <sup>10</sup>	0.0075	0.095	0.016	448
logging	1860-80 (1870)	3.3	0.33	1.7	0.34	12770
Zinc	1928	5.6	0.52	3.1	0.62	21700
Lead	1940	6.7	0.63	3.3	0.68	25400
Copper	1955	7.9	0.59	4.4	0.92	29300

Our results show that there is no real difference in the sedimentation rates between site A and site B based on a mass basis. This underscores the need for density control in presenting sedimentation results and makes our cores incomparable with those from Hatfield Consultants as their results are only available in terms of a depth value. For the A14 core we find that the contemporary sedimentation rate (zinc) is 70 times that of the historical sedimentation rate; conversely, we find that the sedimentation rate at the B11 core site is about 40 times the historical sedimentation rate. The pre-industrial record is 85 % organic and 15 % inorganic sediments. This compares to the post-industrial

---

<sup>9</sup> This is not a true estimate of historical sedimentation rates because it includes all sedimentation to present, even that from human influence.

record of 40 % organic and 60 % inorganic. Obviously there has been a much larger increase in the inorganic sedimentation rate than in the organic rate. Historically there would have been about half a empirical ton per year of sediment added to the lake compared to the contemporary situation where there is about 24 tons of sediment added to the lake each year.

The sedimentation rate measured here is not only influenced by the rate of inputs, organic and inorganic, but also by the rate of decomposition of organic material. Consequently, the sedimentation rates may be affected by decomposition occurring in the sediment and may not truly reflect the impacts of humans. At present there is likely decomposition occurring below the depth at which industrialization shows up; this would cause the sedimentation rate for the post Mazama Ash to appear to be smaller than was the actual case as the continuing decomposition breaks down the remnants of past sedimentation. As a result of this we can begin to appreciate how, unlike the inorganic sediment, the amount of organic material deposited on the lake bottom may be much larger than what is eventually left behind in the sediment.

### 6.3.3. How long will it take to fill in the lake?

There is no precise answer to the question of how long will it take to fill in the lake, or how much shoreline will be lost per year. In addition to knowing what the relevant sedimentation rate is there is the question of the density of the sediment when the lake is filled in. For our purposes we will choose a density of  $850 \text{ kg/m}^3$  which might correspond to an organic soil capable of being stood upon and holding upstanding trees. We will assume the lake currently has a 1 meter thick layer of silty organics with a density of  $120 \text{ kg/m}^3$ , which is what our data supports, and the lake holds  $17,160 \text{ m}^3$  of water when the water level is equal to the weir level (Stewart, 1997). Given this we can conclude we need 42,917,300 kg of sediment to fill the lake (using a lake area of 3.881 Ha). Using the contemporary sedimentation rate based on zinc, it will take about 2000 years to completely fill the lake.

---

<sup>10</sup> The apparent Mazama ash in the AL4 core was never examined in detail, and was much less obvious than that of the BL1 core, for this reason the BL1 core is more accurate historical sedimentation rate.

A more important question may be how quickly the waterline progresses inward. A rough estimate based on the zinc sedimentation rate would see the lake edge move 8 cm per year. In looking at these figures it should be kept in mind that these are rough calculations assuming things stay constant and contain some generalizations about the geometry of the lake. It is also useful to note that if the supply of inorganic sediment is controlled it would be possible to cut the rate of lake edge advancement in half and double the life span of the lake. These figures should be used as a guide line, and are for a density of  $850 \text{ kg/m}^3$  which may be much higher than the actual density of sediment when a lake no longer appears to exist. If a more reasonable density can be determined for peat- filled lakes different filling times apply.

#### 6.3.4. Sources of sediment

In the case of Beaver Lake the inorganic and organic sediments have drastically different sources. In the present day the organic sediment is likely almost completely derived from the die off of aquatic plants. Some logs and branches were detected both on the surface of the sediment and at depth while taking the cores. The proportion of terrestrial vegetation to aquatic vegetation was not determined, but it is likely aquatic plants dominated. The shift of the C:N ratio in the BL1 core from 50 to about 30 indicates that the supply of organic sediment may have shifted in the Holocene. The older, higher C:N ratio is more likely to be associated with a lake basin dominated by terrestrial vegetation. The shift to aquatic sediments appears to have occurred prior to human involvement in the basin. The shift likely occurred when seeds from aquatic plants became introduced into the lake by air or animal transport.

The inorganic sediments have greatly increased since the onset of industrialization and are likely coming from the lake margin areas rather than air transport. The actual source of the sediment is still a bit of a mystery and may merit further investigation. A few likely sources exist. The trails throughout the park are a very likely source of the silt; water frequently washes on top of the trails and is capable of transporting the silts to creeks and the lake margin. Brian Quin (personal communications) estimates that the trails crew puts on about  $4\text{-}5 \text{ m}^3$  of trail gravel per year, to replace the gravel eroded away. A second probable source is the causeway running through the park; vehicles add

large quantities of sand and silt to the roadways, and this material is then easily transported into the basin by rain water. Once the silt is suspended in flowing water it can be transported to the lake where it settles out. A final possible source of inorganic sediment is erosion of the banks of Prospect creek; however, there is limited evidence for this along the channel and this is likely a relatively insignificant source of silt. The inorganic sedimentation of the lake is largely a direct consequence of human activity within the basin and provides the greatest opportunity to slow down the in-filling of Beaver Lake.

## **7. Ecology of Beaver Lake**

As was previously noted, Beaver Lake is the main water body in the Beaver Creek watershed. It is also the only historically natural fresh water body in Stanley Park. Lost Lagoon, the other fresh water body in the park, was constructed in 1916 (Steele 1988). Beaver lake has therefore long been known to play a crucial role in the overall ecology of the watershed, providing unique habitat for numerous species of plants and animals. The object of this section is to provide a brief description of this role.

From January to September 1984, a study on the Beaver Lake-Creek system was completed by Hatfield Consultants Ltd. This study assessed the biological, physical, and water quality parameters of the lake in order to determine the suitability of the system for salmonids. This information will be used to provide general information on the lake. Although there have been changes in the lake in the past 15 years, it is the most accurate data available to us at this time. There is some recent data which was collected by students from Capilano College; although, this data was collected during a single field visit, it was valuable in a number of cases.

### **7.1. *Water quality***

#### **7.1.1. Dissolved oxygen**

The most important chemical parameter in any water body is the concentration of dissolved oxygen, since it determines whether or not aerobic aquatic organisms will be able to live in the water. Every species has a threshold level of required oxygen. Both vertebrate and invertebrate communities will change if the dissolved oxygen content changes.

There are normally three main sources of dissolved oxygen: the air-water interface of the lake, primary production in the lake, and dissolved oxygen brought in by inflowing creeks. At the air-water interface, wind and wave action dissolves air into the water. Since Beaver Lake is so small and sheltered from wind, as well as often being covered with vegetation, this source of oxygen is probably not all that important. It should be

noted that species such as carp and ducks can also contribute to dissolved oxygen concentration by disturbing the lake surface. Another potential source of oxygen is lake primary production, which creates dissolved oxygen through photosynthesis. Dissolved oxygen created by photosynthesis is often important in the very top layer of a lake during the summer (Wetzel 1983). This is because there are often algae and phytoplankton blooms near the surface. In Beaver Lake, the aquatic macrophytes appear to out-compete the phytoplankton for light, so this trend is not seen.

For Beaver Lake, the majority of the dissolved oxygen originates in Prospect Creek, the inflowing creek. Prospect Creek is much higher in dissolved oxygen than the lake, as most creeks are, since there are many more waterfalls and riffles which allow the water and air to mix. From work done by Capilano college students (Lashek *et al.* 1998), it is easy to see the trend of decreasing DO as they move away from the mouth of Prospect Creek across the lake to the Beaver Creek outflow (Figure 7-1).

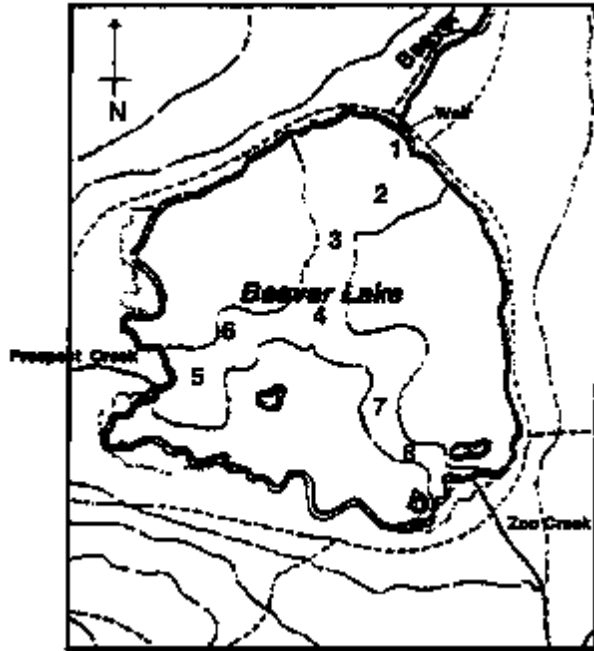

Figure 7-1 Dissolved oxygen sample sites (Lashek *et al.* 1998)

Table 7-1 Dissolved oxygen values (Lashek *et al.* 1998)

Station	Surface Dissolved Oxygen (ppm)
1	0.86
2	0.9
3	4.31
4	3.78
5	11.76
6	5.71
7	N/A
8	N/A

From Table 7-1 we can also get a general idea of the oxygen values for the lake as a whole. The most significant values are those found closest to the weir (locations 1 and 2). These are very low oxygen concentrations (~0.9ppm), especially compared to the numbers that the Hatfield report gives for the same location. The lowest monthly average reported by Hatfield is approximately 3ppm. If both data sources are accurate, they indicate a significant reduction in water quality in the past 15 years. This means that the

lake is even less suitable for salmonid habitat than it was in 1984, particularly at this location. The higher oxygen levels that Lashek *et al.* (1998) found closer to the mouth of Prospect Creek may indicate habitat which is within limits of salmonid survival requirements; however, their study was done in May. Even lower oxygen values would be expected in August.

#### **7.1.1.1. Factors which affect dissolved oxygen**

The capacity of water to absorb oxygen (and other gases) is related to the temperature of the water. The saturation concentration of oxygen decreases with temperature. This relationship is one of the factors which causes the dissolved oxygen concentration to be lower in the summer than the winter. Thermal stratification also affects the DO concentrations in some lakes.

The Biological Oxygen Demand (BOD), which is the amount of oxygen used by the organisms in an aquatic system, is also a very important factor for the DO concentrations in Beaver Lake. One of the chief contributors to BOD is organic matter. As bacteria and benthic organisms consume this organic material, they use up the oxygen in the water column and sediments. This oxygen is then not available to other organisms such as fish. Since Beaver Lake produces a lot of organic material, the BOD is fairly high. The highest BOD in Beaver Lake probably occurs at the sediment/water interface. This is because Beaver Lake produces more organic material than it decomposes, resulting in a net sedimentation on the lake bottom. This gives rise to a large benthic oxygen-using community. For the summer of 1984, Hatfield found that there was an average of 12,000 macrobenthic organisms per square metre of substrate.

#### **7.1.2. Temperature**

The highest temperature recorded by Hatfield was 18.5 °C, which occurred in August. In their work in May 1998, Lashek *et al.* (1998) recorded a high temperature of 15.5 °C. This value is quite high considering how early in the season the work was done. This may be due to the fact that 1998 was an exceptionally warm summer.

### 7.1.3. Other factors

Hatfield (1984) tested the lake water for a number of other water quality characteristics and found them to be within the ranges acceptable for salmonid survival. These characteristics included pH (~6.1), alkalinity (12-16 mg/L CaCO<sub>3</sub>), hardness (soft water) and nonfilterable residues (mostly <25mg/L), as well as phosphorus, nitrogen, and silica compounds.

### **7.2. Anaerobic respiration**

When the amount of dissolved oxygen is very low, anaerobic respiration takes over as the primary type of metabolism. Organisms which respire anaerobically use other molecules besides oxygen as their electron acceptor and produce things besides CO<sub>2</sub>. An important product in Beaver Lake is hydrogen sulphide (H<sub>2</sub>S) gas, which is produced in the sediments of Beaver Lake. The importance of this gas is in its toxicity to many species. According to Hatfield, the levels of H<sub>2</sub>S do not appear to be significant (<0.01mg/L), except perhaps in the winter when the lake was frozen over while anaerobic respiration was ongoing in the sediments. We noticed a rotten egg smell while we were on the lake taking our core samples. The smell seemed quite strong, so perhaps the H<sub>2</sub>S levels have risen in the last 15 years. This is something which could perhaps be investigated by another project. Another product which may be important is methane (CH<sub>4</sub>) gas, but no one has done measurements of this.

### **7.3. Macrophytes**

Macrophytes are described by Wetzel (1983) as large aquatic plants. They often include seaweed, as well as the vascular aquatic plants which are most important in Beaver Lake. In their report, Hatfield includes a map of the vegetation cover on the lake surface (Figure 7-2). Although this information may be slightly outdated, it gives us an idea of what species are predominant. The introduced white water lily (*Nymphaea spp.*) covers approximately 50% of the surface area. The yellow water lily (*Nuphar sp.*) also covers a significant area of the lake and the small lily called water shield (*Brasenia schreberi*) is interspersed on the surface. Buckbean (*Menyanthes trifoliata*) is another aquatic macrophyte which covers a large area of the lake. The *Nymphaea* species are not

native to this area, so their presence in the lake can be directly associated with the water lily introduction of 1936. All the other species of macrophytes can be found in the area, so it is harder to determine if they are truly native to the lake or were also introduced. Buckbean is the exception to this as it is very unlikely to have been introduced. The introduced water lilies are commonly blamed for increasing the sedimentation rate, and therefore the infilling of the lake. Although we found that the overall sedimentation rate has increased in the past 100 years, it does not appear to be as great of an increase as was formerly thought. The inorganic sedimentation rate plays a much larger role than was believed to be the case.

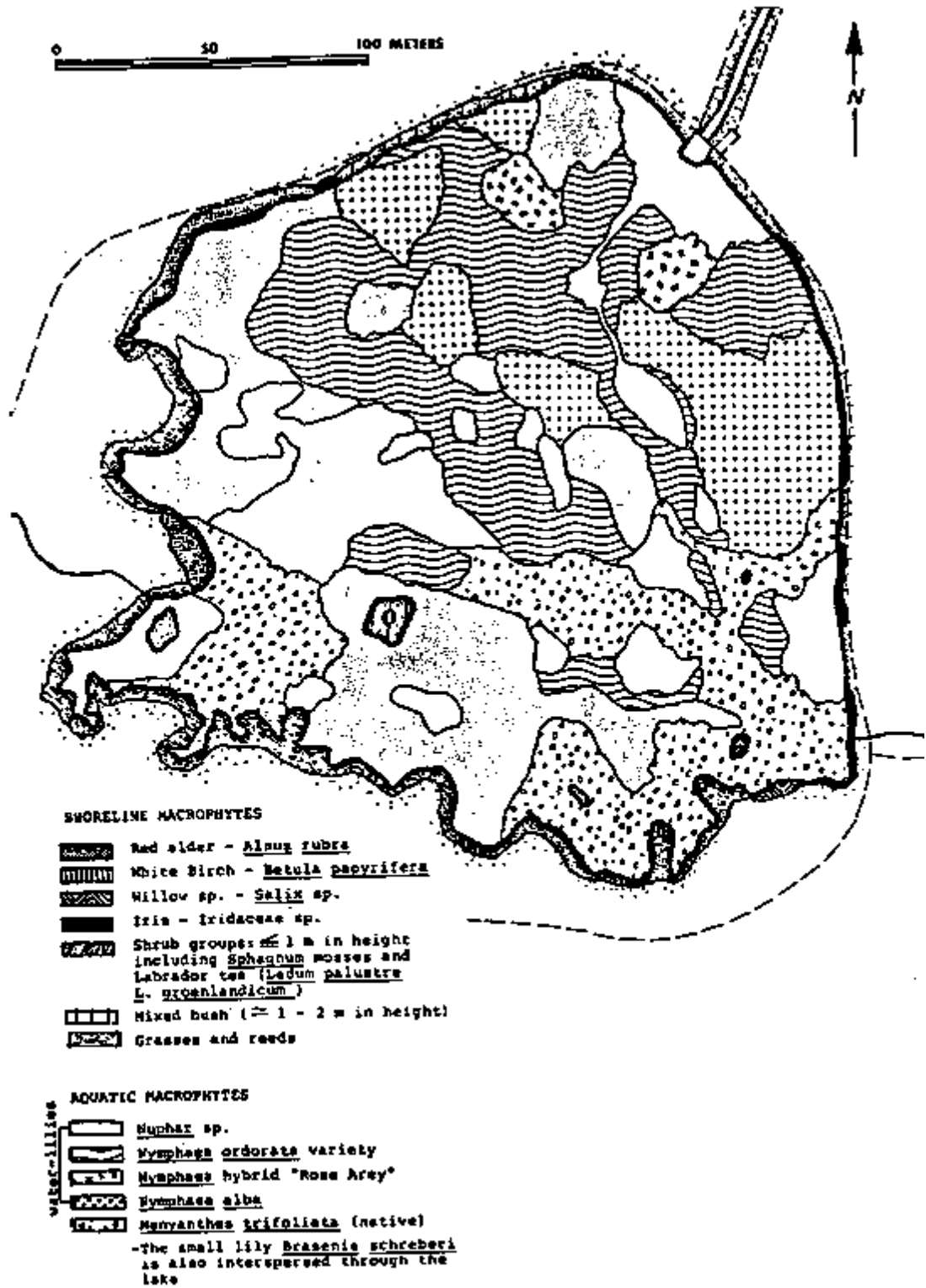

Figure 7-2 1984 Vegetation on Beaver Lake (Hatfield Consultants 1984)

## **8. The “natural” basin.**

This section is intended to be a short description of what the watershed might look like in the absence of human interference and is focused on putting aside some misconceptions about the watershed.

The hydrology of the basin would be similar except the creek would stop flowing for about two months during the summer and the lake would drop in height during this time. The stream flow recession might be slightly slower than is presently the case as there would be no trails, ditches or artificial creeks increasing the channelization of the basin. The lake itself would be lower at times of peak runoff than is presently the case as the weir would not exist. In addition to this the total amount of water flowing out of Beaver Creek during a year would be at least four times less than is presently the case

The depth of the lake would at best be only slightly deeper than is presently the case. The raising of the water level has roughly equaled the human induced sedimentation in the lake, such that the depth of water in the basin has remained relatively constant. However, the area of the lake would likely be larger. The elimination of creek flow during the summer months would cause the lake to become warmer and more anoxic. Fish would be infrequent visitors to the basin and only very marginal populations would survive in the streams and lake. The carbon to nitrogen ratios indicate that the lake would be dominated by aquatic macrophytes as is the case today. The species would be different, and there may be slightly less of the lake covered by these species, but the majority of the sediment in the lake would come from the aquatic vegetation.

The forest would be dominated by mature coniferous forest and there would be very little inorganic sediment entering the lake. The vegetation around the lake edge would likely be more typical of a wetland which goes through seasonal drying and wetting periods, and there may be more extensive areas of bog.

Having said all this, it is important to realize that in general the human impacts of the basin have left the system relatively intact and succession still dominates the

landscape. This is a significant achievement given the basins location within the city of Vancouver.

## Integration of results: summary

This section provides a summary of the major interactions that we attempted to look at in the Beaver Lake system (Figure 9-1).

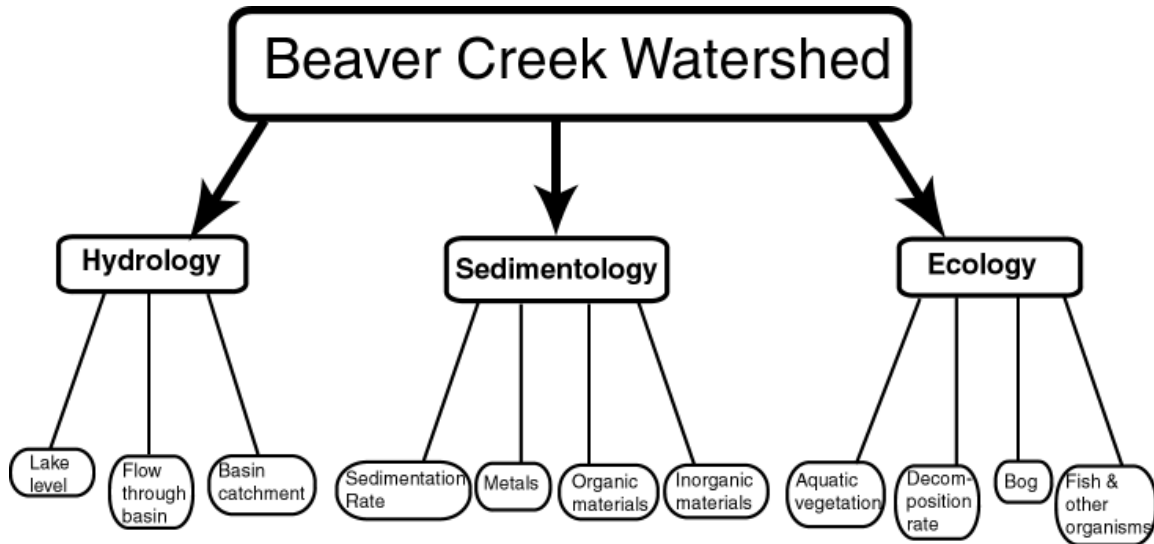

**Figure 9-1 Interactions within the Beaver Creek watershed**

### **8.1. Lake level and vegetation**

The water level and degree of seasonal fluctuation will have an impact on the degree of encroachment of terrestrial vegetation. In Beaver Lake, fluctuations in the lake level is nearly eliminated by the addition of city water to the system. Without this, the lake level and stream flows would be significantly reduced during the summer season. This lake level reduction would result in exposed soil which allows the encroachment of more terrestrial species of vegetation. The computer model indicates that the reduction would begin in June most years if the city water was completely eliminated. This is a time of year when plenty of plant species are flowering, making colonization very likely. The encroachment rate will increase the earlier the lake level is reduced and the longer it stays reduced.

### **8.2. Lake level and bog**

The unique Sphagnum bog system which is found on the eastern side of the lake will also be affected by the lake level fluctuations. The bog area likely shrunk in area due to flooding when the lake level was raised early in the century. It is hard to say how

exactly the bog would be affected. Allowing the lake level to fluctuate could potentially increase the bog area since the area would no longer be flooded all year. The main threat to the bog area is currently the encroachment of more terrestrial species. So it is also possible that allowing the lake level to fluctuate will actually cause a decrease in the bog area.

### **8.3. Lower flows through Beaver Lake and fish**

A decrease in the volume of water flowing through the basin is going to decrease the mixing of the lake. With a decrease in the mixing of the lake, the levels of dissolved oxygen will decrease and this will impact the fish. How much the water has to be reduced in order for the lake to become uninhabitable for fish is unclear. If the lake receives no water for a period of a couple of months, which is what the model predicts, then it is unlikely most fish could exist in the lake, especially oxygen sensitive fish such as Cutthroat trout and Coho salmon.

Reduced flow through the lake also impacts the temperature regime which is of critical importance to the fish. A reduction in the water supply may cause the lake to become warm enough from solar heating that most fish would not survive. Some temperature resistant fish such as carp may continue to exist.

### **8.4. Lower flows in Beaver Creek and fish**

The water flowing through Beaver Creek is clearly important for the fish which live in that water. The flow in the creek creates the fish habitat, supplies the food, and keeps the water cool and aerated. In the creek the temperature problem is associated with the supply of warm water from the lake rather than solar heating. The low flow condition, where the water flows completely through the subsurface, could actually be beneficial for the fish if we ignore the consequences of low flow in the lake. As long as there are deep enough pools for the fish to live in during the periods of low flow, the gravel would cool the water as well as aerate it as the water flowed through the subsurface. There would also have to be a significant amount of subsurface flow in order for this to be feasible.

In general creeks do not have the same problem with aeration as the flow is always turbulent and mixes with the surface. Having said this it is possible to increase the oxygen content in creeks by increasing the mixing of the water with the atmosphere. The fish in the creek are more dependent on the quality of water coming into the creek than they are on the actual amount of water in the creek.

### **8.5. *Sedimentation rate and lake level***

Both the organic and inorganic sedimentation contribute to the overall sedimentation on the lake bottom. This sediment slowly decreases the lake level. The sedimentation rate is very important as it provides an estimate of the time it will take the lake to fill in. We found the sedimentation rate to be approximately  $0.57\text{kg/m}^2/\text{yr}$ .

### **8.6. *Aquatic vegetation and organic sedimentation***

The aquatic vegetation is a significant contributor to the overall sedimentation rate in the lake. The leaves die off at the end of the growing season, and since they do not decompose fully, they accumulate on the bottom of the lake. This results in the low density organic sedimentation which has been blamed as the major contributor to the sedimentation rate. We found that our cores were composed of approximately 40% organic and 60% inorganic near the surface.

### **8.7. *Sedimentation and decomposition rate***

The decomposition of organic substances is carried out by a number of different lake organisms and the rate of this process is determined by a number of different factors including the temperature and oxygen levels. Since the oxygen concentrations are higher in the water column, a deeper lake level results in a faster initial decomposition rate. The process continues in the sediments, but it is much slower because of the anaerobic conditions. The plant material which does not get decomposed results in sedimentation on the bottom of the lake. It would be interesting to find out the actual decomposition rate of the Beaver Lake sediments.

### **8.8. *Catchment basin and inorganic sedimentation***

The vast majority of the inorganic sedimentation entering Beaver Lake originates in the catchment basin and runs in as a result of stormflows. This inorganic sedimentation is approximately 160 times what it was before the trails and roads were built through the watershed. This is much larger than the increase of approximately 10 times seen in the organic sediments, leading us to believe that the sources of inorganic sediment are more important to deal with than the organic sources.

### **8.9. *Catchment basin and metal contaminants***

The runoff from the causeway results in metal contaminants entering the Beaver Lake system. We found that there was a very distinct increase in the metal concentrations in the sediment record. By correlating the depth of this increase to the time when the causeway was completed, we can use the metals to estimate the sedimentation rate in the lake. The metal contaminants in Beaver Lake were not found to be at high enough levels to be considered dangerous to wildlife, but if they continue to enter the basin, they could accumulate. The oil-water separators which are to be installed with the causeway expansion are a good way of dealing with this problem.

## 9. Framework and values

Taking into account the principles of ecosystem management, the state of the watershed, and our own ideas and concerns, we feel it is necessary to state a set of values on which we base our recommendations. We also believe that in order to make effective value judgements it is necessary to specify the framework within which the ecosystem exists. First, this watershed is an urban watershed existing within a park. The watershed is therefore subject to influences and stresses that would not be present elsewhere. For example, there are roads running through the basin that receive continuous use. Trails have been constructed throughout the watershed for the many people who visit the area each day, the public. Not only does this public visit the watershed but also, in many cases, cares about the future of the watershed and has opinions regarding how it should be managed. The public has considerable influence regarding the management of the watershed because without them, the park itself would find it difficult to exist. We believe that value judgments and management decisions made outside of this context will not be sustainable. Recognizing therefore that we are working within this framework, we value the following things:

- **ecosystem processes occurring within the watershed, specifically the process of natural succession**

We believe that processes occurring within the watershed, although influenced by humans, have retained basic qualities that would exist in a system removed from human influence. That is to say, all lakes move through a successional process from lakes to terrestrial ecosystems. We recognize this process as being paramount to the idea of preserving the ecosystem in its current state, i.e. as a lake.

- **educational/interpretive programs**

We believe there are many educational opportunities within the Beaver Creek ecosystem and that relating this information to the public is crucial to the survival of the ecosystem. More specifically, we believe that successional patterns themselves hold great interpretive value. These processes have shaped much of Canada's landscape

and the Beaver Creek watershed presents a unique opportunity for the public to learn about these processes “in their own backyard”.

- **recognition of past and present human impacts**

We think it is important to recognize past impacts humans have had on the watershed as well as the ongoing human impacts on the system. To manage the watershed effectively today, we must understand and recognize the historical and current role of human interaction. Recognizing the role humans play in the system, including the disturbances they create, is also a valuable educational tool.

- **responding to past human impacts**

While we value the process of succession in the Beaver Creek watershed, we also believe it is important that succession due to human impact does not proceed at an alarming rate. We have sped up the process of succession and as a result, completely pulling out of the watershed (i.e. turning the water off) will result in a rapid transition to a terrestrial ecosystem of some form.

- **goals of BLEEP**

The group values the goals of the Beaver Lake Environmental Enhancement Project as a means of public input into the management of the system. BLEEP has developed a set of goals and objectives based what they believe to be the most important issues within the watershed. We respect these goal and believe they are important in ensuring that any decisions made are sustainable.

- **limit future impacts**

We believe it is important now to limit any other major human disturbances within this watershed. We believe it is important to interfere with the current system as little as possible, keeping in mind all values stated above.

## **10. Recommendations**

### ***10.1. Recommendation #1: Do not dredge the lake***

Dredging portions of Beaver Lake has been proposed as a potential solution to the sedimentation problem. This solution would be an effort to stop the succession process occurring in the lake. In addition, questions arise as to whether this solution would be effective in prolonging the life of the lake.

#### **10.1.1. Scientific evidence**

Sedimentation rates calculated based on estimated dates within the sediment cores show that previous studies have overestimated the speed of this process. The sedimentation was previously thought to be mainly organic, but our data have shown a large inorganic sediment source. This problem can be addressed without dredging the lake. Dredging itself may not be effective in extending the life of the lake as only portions of the lake would be dredged, creating channels. A similar system of channels would exist in the lake even if dredging were not carried out. As the organic layer makes up a relatively small portion of the sedimentation, the inorganic material (silts) in the lake would have to be dredged in order for the dredge to be effective. Dredging the lake increases the possibility for heavy metals in the lake to become resuspended and therefore more available for uptake by plants. Lastly, dredging the lake would cause a huge disturbance to the entire ecosystem.

#### **10.1.2. Logistics**

Dredging the lake would entail a large capital expense and would require maintenance and continuous funding over time. The issue of heavy metals and the possibility of resuspension would need to be researched and dealt with in greater detail. The dredgeate would need to be deposited somewhere and restrictions on heavy metal concentrations will likely limit available options. Lastly, the lake is not readily accessible to the heavy machinery required in dredging the lake.

### 10.1.3. Values

This solution does not allow the process of natural succession to occur. It creates a large human disturbance over the entire ecosystem.

*We do not believe dredging Beaver Lake to be a viable option for management of the basin. Dredging would drastically alter the current system and there are doubts with regard to how effective a dredge would be. It is logistically difficult and goes against one of our main values, that of allowing ecosystem processes to occur.*

### **10.2. Recommendation #2: Reduce the inorganic sedimentation rate**

The inorganic sedimentation rate is causing problems for both Beaver Lake and Beaver Creek. A decrease in the supply of inorganic sediment could reduce the sedimentation rate in Beaver Lake by 50 % and create much better fish habitat in Beaver Creek.

#### 10.2.1. Scientific evidence

The sediment cores showed that the inorganic sediment has increased from being about 15 % to 60 % of the sediment. This increase has direct implications for the sedimentation rate in Beaver lake. If the inorganic sediment supply was controlled and returned to about 15 % the sedimentation rate would be cut in half. In Beaver Creek a reduction of gravel in the stream would enable scour to occur at bends and around pieces of LWD to create pools along the stream. These pools would create fish habitat within the creek.

#### 10.2.2. Logistics

The supply of gravel for the creek comes from the fill used in the restoration work and from the trails along the channel especially from around the weir. The supply of gravel could be reduced by better management of storm runoff along ditches and through, rather than over the weir.

The source of the inorganic sediment filling in the lake is not know, and as such limiting the supply of sediment is not immediately possible. The sediment appears to

come from the lake edge and most likely comes from both the trails in the park and from dust on the causeway. The trails could be boardwalked or reconstructed with French drains and geotextiles to control the supply of sediment off the trail surfaces. Both the runoff from the trails and from the roads could be run through settling ponds with geotextiles in place to collect silt. This process, especially the resurfacing of the trails, may be expensive.

### 10.2.3. Values

A reduction in the supply of sediment would be in accordance with our values as it would not be a huge disturbance. It would recognize the presence of human impacts and would be an attempt to limit the impacts. It would help to reduce the sedimentation rates and increase the longevity of Beaver Lake, this would coincide with the goals of BLEEP.

*A reduction in the supply of inorganic sediment seems to be a feasible, relatively easy solution which would benefit the system. Geo-textiles might be a better solution than boardwalks to be used in resurfacing the trail surface as using these would leave the trail relatively unchanged. Cyclists are likely to be apprehensive about the introduction of boardwalks in place of trails as they will be slippery to ride on. A set of settling ponds would further reduce the supply of silt to the lake. Similar efforts could be used to control sediment supply to the creek.*

### **10.3. Recommendation #3: Develop an interpretive program relating to ecosystem processes within the Beaver Creek watershed.**

Interpretive programs within parks serve to educate the visiting public about the area. A good interpretive program gives visitors the opportunity not only to enjoy the beauty of the area, but to learn about the system and processes governing its existence. It provides a medium to present interesting historical information as well as current issues surrounding the park. Interpretive programs may play a crucial role in public involvement in the area.

### 10.3.1. Scientific evidence

It is clear that succession is occurring in this ecosystem. Beaver Lake will eventually be filled in and will progress toward a terrestrial ecosystem. There are many interesting processes taking place that accompany this transition. Through our research, we have uncovered some very interesting information with regard to the historical record of sedimentation in the basin as well as ideas as to what the basin may have looked like historically and what it would look like if human influence were eliminated. Furthermore, the presence of a freshwater ecosystem in an urban setting is rather unique. Therefore, emphasis on this ecosystem while it still exists and on its natural progression toward a terrestrial ecosystem is an invaluable educational tool. Finally, it is important to educate the public regarding the impact people have had on the basin in the past, and the continuing influence that we exert on it.

### 10.3.2. Logistics

This recommendation would be relatively inexpensive. It requires the basic design and implementation of an interpretive program. One major requirement is creative minds to put the program together. Mirror Lake in Yosemite National Park may be able to serve as a template.

### 10.3.3. Values

This recommendation acknowledges past and present human impacts on the system. Recognition of these impacts would form an integral part of the interpretive program. Making people aware of past human disturbances as well as ongoing impacts that they are a part of allows us to understand humans as part of any ecological system. The recommendation emphasizes the education/ interpretive values we have previously cited as being crucial to this urban watershed. Designing and implementing such a program would not create a large disturbance on the system and responds to BLEEP's goal of maintaining and enhancing the educational value of the watershed.

*Implementation of an interpretive program would enhance the public's understanding of ecological processes, both in terms of aquatic systems and successional patterns. In addition, it would help people to learn about and understand the role humans play within these ecosystems.*

#### **10.4. Recommendation #4: Decrease city water supply**

In order to achieve a hydrological regime that resembles the one described in the previous section, it would be necessary to completely remove the flow of city water which presently supplies the basin on a year-round basis. Since the present supply of city water is quite large relative to the natural input of water from precipitation, this action may have sudden drastic effects on ecosystem functions. Furthermore, the potential for interpretive programs that could teach the public about fish habitat and lake ecosystems will be lost. Therefore, we recommend taking intermediary action. First, completely remove the supply of city water into the basin during the winter months. Second, set up an outflow point of city water at the top of Beaver Creek which can be turned on whenever the level of water falls below a critical level.

##### **10.4.1. Scientific evidence**

The amount of water being added to the hydrological regime through a city water pipeline was measured to be  $0.184\text{m}^3/\text{s}$  during the winter months (Wu et al., 1999). Once converted into an equivalent daily rainfall depth, this volume of water represents a daily rainfall of 20mm. The summer input values were not measured but are known to be higher than winter input levels.. On an annual basis, the volume of city water added is over four times greater than the annual precipitation. This dramatically affects the lake basin. Instead of fluctuating between a full basin in the winter and a drawn down marsh in the summer, the lake remains as a relatively full basin year-round due to the city water input. The proposed recommendation attempts to maintain an annual fluctuation without allowing the lake to completely dry up, thus maintaining enough water to support an aquatic ecosystem. This is a valuable resource for educational purposes in an urban park. The constant addition of city water also artificially cools and aerates the lake and the

creek. Some cooling and aeration is important, but is unnecessary on a year-round basis. Furthermore, adding water to the basin year-round is a complete waste of chemically treated city water.

#### 10.4.2. Logistics

Meeting this recommendation would require the implementation of a new system which inputs water directly into Beaver Creek at the junction with the lake. Furthermore, additional monitoring would be necessary so that the timing of the input water would coincide with the critical level in the creek which is required to maintain a small fish population. In order to determine this minimum level, further research is required. A final logistical problem that would need to be dealt with is educating the public about the natural flow regime. This would prevent regular park users from being shocked at the different patterns of water flow and lower lake levels.

#### 10.4.3. Associated values

Decreasing the city water supply allows some natural successional and natural processes to occur (i.e. lake level fluctuations and creek dry up in summer). It allows for fish to exist in the system which enhances the interpretive value of the area. It recognizes present human impacts while ensuring that succession due to human impact does not occur at an alarming rate. Lastly, it does not create a huge disturbance to the area.

*The current volume of water entering the basin is unnecessary. Decreasing the city water supply would decrease human influence on the basin while still allowing an open body of water and fish habitat to remain.*

### **10.5. Replacement of the weir**

The weir at the outflow of Beaver Lake needs to be replaced as it is old, incapable of passing storm event discharges, and impassable to fish.

### 10.5.1. Scientific evidence

The outflow culverts at the weir are too small and are incapable of passing large rain fall events. This has caused frequent flooding of the trail area and has introduced large quantities of sediment into Beaver Creek. The main weir is estimated to be able to pass  $0.6\text{m}^3/\text{s}$  while the secondary weir is likely able to pass  $0.13\text{m}^3/\text{s}$  when the stopping boards are in place (Wu *et al* 1999). This total discharge ( $0.73\text{ m}^3/\text{s}$ ) is far smaller than the 100 yr. flood ( $3.3\text{ m}^3/\text{s}$ , Wu *et al* 1999) for which the weir structure should be built. In addition, the logs which hold the weir in place are becoming old<sup>11</sup> and could stand to be replaced. Lastly, an inspection of the culverts in the weir found their slopes to be 18 and 8 percent, for the main and secondary culvert, respectively. These slopes are much too steep for fish to pass. It is generally accepted that culverts up to a few percentage points are at the limit for fish passage.

### 10.5.2. Logistics

In replacing the weir plans like those described by Wu *et al* (1999) would likely be reasonable to follow. One of the major problems in replacing the weir is finding the funds to do it effectively. The weir structure is best replaced/ modified by an open channel structure flowing in the location of the secondary culvert. This may not be cheap or simple to build. This structure will not be straight forward as the overall gradient within which the structure must fit is steep, and the structure needs to prevent erosion of the banks of the creek, while being passable to fish. A step-pool structure might work well. The trail itself will also have to be modified, likely by putting in bridges across the channel. When replacing the structure it is likely best to set the new outflow level equal with the level at the bottom of the contemporary weir as this is the level the lake has adjusted to since the lake was originally raised.

---

<sup>11</sup> The issue of just how old and how much the water level was raised is unknown, one possible way of determining this is constructing a dendrochronological (tree ring) record for the park and comparing the tree rings of the logs making up this weir with this record.

### 10.5.3. Values

This recommendation satisfies educational and interpretive values as it will increase the fish habitat and make the weir structure appear more natural. In addition to this a new weir which is passable for fish would enable natural migration between the creek and the lake to occur. The construction of a new weir would also help to remove past human impacts and prevent new ones by reconstructing lake outflow conditions.

*The replacement of the weir is inevitable and should be done in a manner that most mimics the natural processes and makes it possible for fish to move from Beaver Creek to Beaver Lake.*

## **11. Conclusions**

When considering the actual implementation of our recommendations, we are struck by the difficult decisions the people of the BLEEP community group are faced with. A general approach to the management of the basin must be committed to. There is obviously a fundamental difference between allowing the lake to fill in and trying to maintain the lake as an open water body by dredging it. This decision will have very important impacts on the future management of the watershed. We think that by allowing the lake to fill in and setting up an interpretation program surrounding the successional processes seen in the basin, BLEEP could lead the way in implementing a more holistic approach to the management of urban parks and watersheds by recognizing the role that people play in natural ecosystems.

## Acknowledgments

We would like to thank the many people who contributed to the success of this project. In particular, many thanks to Dr. Mike Church (UBC Geography Dept.) for his valuable input and use of lab facilities, and to Dr. Les Lavkulich and Carol Dyck (UBC Soil Science Dept.) for constructive input and use of the soil chemistry lab for metals, nitrogen and carbon analyses. Our thanks also to Dr. Ken Hall (UBC Civil Engineering Dept.) and Dr. Burbee (UBC Botany Dept.) for equipment and sampling advice. Thanks to Dr. Black and Elyn Humphreys (UBC Soil Science Dept.) for assistance with the hydrology model. Many thanks as well to Mike MacIntosh and the members of the Beaver Lake Environmental Enhancement Project for their interest and input into the project. In addition, we would like to acknowledge the following people for their assistance with various aspects of the project:

Margaret North (UBC Geography Dept.)

Dr. Steyn (UBC Geography Dept.)

Brian Menounos (UBC Geography Dept.)

Shona Ellis (UBC Botany Dept.)

Jason Garratt

## 12. List of References

- Aase, J.K. and S.B. Idso, 1978, A comparison of two formula types for calculating longwave radiation from the atmosphere, *Water Resource Research*, Vol. 14. pp. 623-625.
- Anderson, M. and T. Burt, 1980, Interpretation of Recession flow, *Journal of Hydrology*, vol. 46, 89-101.
- Arya. 1988. Introduction to Micrometeorology. Academic Press.
- Ashmore, P.E. 1991. How do gravel-bed rivers braid? *Canadian Journal of Earth Sciences*. 28:326-41.
- Ballard, Tim. 1997. Lecture in Soil Science 200, UBC.
- Ballard, Tim. Personal Communication, 1999. Department of Soil Science, UBC.
- Barnes, B., 1939. The structure of discharge-recession curves. *Transactions of the American Geophysics Union*, 20: 721-725
- Beaver Lake Environmental Enhancement Project (BLEEP). 1996. Statement of Vision and Goals. Not published.
- Beese, W. J. 1989. Stanley Park Regeneration Program: Folio I. Forest Management Plan. MacMillan Bloedel Ltd. Prepared for Vancouver Board of Parks and Recreation.
- Beese, W. J. 1989b. Stanley Park Regeneration Program: Folio II. Support Reports. MacMillan Bloedel Ltd. Prepared for Vancouver Board of Parks and Recreation.
- Black, T.A. 1979, Evapotranspiration From Douglas Fir Stands Exposed to Soil Water Deficits, *Water Resources Research*, Vol. 15(1):164-170.
- Boss, Mike. Personal Communications, phone interview, GVRD water district, February 19th, 1999.
- Brunner, R. D. and T. W. Clark. 1997. A Practice-based Approach to Ecosystem Management. *Conservation Biology*. 11(1):48-58.
- Callicott, J. B. and K. Mumford. 1997. Ecological Sustainability as a Conservation Concept. *Conservation Biology*. 11(1):32-40.

Church, Mike. Personal Communication. 1999. Department of Geography, University of British Columbia.

Church, Mike. Personal Communication B. 1999. Geography 205 laboratory. Department of Geography, University of British Columbia.

Coastal River Environmental Services. 1995. Comparative Environmental Assessment of Lions Gate Crossing Options Related to Stanley Park and First Narrows: Fisheries and Aquatic Resources. Prepared for Ministry of Transportation and Highways. Not Published.

Coulson, J., B. McDonald, and T. Worcester. 1998. Characterization of the Beaver Lake Bog Areas, Stanley Park, Vancouver. Capilano College Environmental Sciences Program. Not Published.

Freeze, R.A., and J.A. Cherry. 1979. Groundwater. Prentice-Hall Inc. Englewood Cliffs, New Jersey.

Frissell, Christopher A., and David Bayles. 1996. Ecosystem Management and the Conservation of Aquatic Biodiversity and Ecological Integrity. *Water Resources Bulletin*. 32(2):229-240.

Geological Survey of Canada. 1979. Surface Geology: Vancouver. Map number 1486a, scale of 1:50 000.

Giles, D.G., T.A. Black, and D.L. Spittlehouse. 1985. Determination of growing season soil water deficits on a forested slope using water balance analysis, *Canadian Journal of Forest Research*, Vol. 15(1): 107-113.

Greater Vancouver Regional District (GVRD). 1974. Greater Vancouver. Map number 4b, scale 1:15 500.

Grumbine, E. R. 1994. What is Ecosystem Management? *Conservation Biology*. 8(1):27-38.

Grumbine, E. R. 1997. Reflections on "What is Ecosystem Management?" *Conservation Biology*. 11(1):41-47.

Hatfield Consultants Limited. 1984. Beaver Lake-Creek Enhancement Study. Prepared for Vancouver Board of Parks and Recreation and Salmonid Enhancement Program: Department of Fisheries and Oceans. Not Published.

Hatfield Consultants Limited, 1985. A Technical and Economic Feasibility Study of The Beaver Lake/Creek Enhancement Project, Prepared for Vancouver Parks and Recreation Board and Salmonid Enhancement Program: Fisheries and Oceans. Not Published.

- Heathcoate, Isobel W. Integrated Watershed Management: Principles and Practice. 1998. John Wiley & Sons, Inc. Toronto.
- Hicken, E.J., and G.C. Nanson, 1984, Lateral migration rates of river bends. *Journal of Hydraulic Engineering* 110, 1557-67.
- Knighton, D., 1998 Fluvial Forms and Processes: A New Perspective, Arnold, Great Britain.
- Lashek J., T. Schmidt, and T. Scoffield. 1998. A study of disposal options & sediment quality for proposed dredgeate in Beaver Lake. Capilano College Environmental Sciences Program. Not Published.
- Lavkulich, Dr. L. Soil Chemistry Laboratory Methods. Department of Soil Science, UBC.
- Matthews, Rolf. 1999. Personal Communication. Professor, Simon Fraser University.
- Mackenzie, S. H. 1996. Integrated Resource Planning and Management: The Ecosystem Approach in the Great Lakes Basin. Island Press: Washington, DC, USA.
- McCallum, D.W., and K.J. Hall. 1998. Limitations of Sediment Quality Surveys: A Case Study of an Urban Watershed in British Columbia, Canada. *Water Science Technology*. 38(11):201-208.
- McMartin, P. Date unknown. Rescuing Beaver Lake from chokehold means dredging the lilies. *Vancouver Sun*.
- Mitsch, W.J. and J.G. Gosselink. Wetlands. 1986. VanNostrand Reinhold Company Inc. Agincourt, Ontario.
- Munawar, M. and G. Dave. Development and Progress in Sediment Quality Assessment: Rationale, Challenges, Techniques & Strategies. 1996. SPB Academic Publishing. Amsterdam, The Netherlands.
- N.D.. Lea Consultants Ltd. (1998). Drainage and Utility Relocation: Highway 9, Lions gate Project. Prepared for the BC Transportation Financing Authority. Map number: R1-377-H355 - not published
- Nakamura, F. and F. Swanson, 1993, Effects of Coarse Woody Debris on Morphology and Sediment storage of a Mountain Stream System in Western Oregon, *Earth Surface Processes and Landforms*, Vol 18, 43-61.

Nuszdorfer, F. C., K. L. Kassay, and A. M. Scagel. 1985. Biogeoclimatic units of the Vancouver Forest Region. BC Ministry of Forest and Lands. Research Branch map, scale of 1:500 000.

Oke, Tim. Personal Communication. 1999. Department of Geography, University of British Columbia.

Post, D.A. and A.J. Jakeman, 1996, Relationships between catchment attributes and hydrological response characteristics in small Australian mountain ash catchments. *Hydrological Processes*, Vol 10, pp. 877-892

Pott, Ute. Assessment of Atmospheric Heavy Metals By Moss Monitoring with *Isoetecium Stoloniferum* Brid. in the Fraser Valley, B.C., Canada. Master's Thesis, Biology, UBC, 1995.

Priestley, C. H. B. and R.J. Taylor, 1972. On the assessment of surface heat flux and evaporation using large-scale parameters. *Monthly Weather Review*, Vol 100: 81-92.

Quin Brian. 1999. Personnel Communication. Stanley Park Horticultural crew Foreman.

Reasoner, M.A. and R.E. Healy, Identification and significance of tephras encountered in a core from Mary Lake, Yoho National Park, British Columbia, *Canadian Journal of Earth Sciences*, Volume 23, pp. 1991-1999

Robertson and Belchuys. Comparative Environmental Assessment of lions Gate Crossing Options Related to Stanley Park and First Narrows: Wildlife Resources. Prepared for Ministry of Transportation and Highways. Not Published.

Schaefer, V. and A. Chen. 1988. *The Natural History of Stanley Park*. Discovery Press: Vancouver.

Smakhtin, V.Y., K. Sami and D.A. Huges, 1998, Evaluating the performance of a deterministic daily rainfall- runoff model in a low-flow context, *Hydrological Processes*, Vol 12. pp. 797-811

Smoley, C.K. 1992. *Methods for the Determination of Metals in Environmental Samples*. Environmental Monitoring Systems Laboratory Office of Research and Development. U.S. Environmental Protection Agency: Cincinnati, Ohio, USA.

Spittlehouse, D.L. and T.A. Black, 1981, A growing seasonal water balance model applied to Douglas Fir stands, *Water Resource Research*, Vol 17(6). pp. 1651-1656.  
Stanley, Jr., T. R. 1995. Ecosystem Management and the Arrogance of Humanism. *Conservation Biology*. 9(2):255-262.

Stanley Park Task Force. 1992. Final Report. Vancouver Board of Parks and Recreation.

Steele, M. 1985. The Stanley Park Explorer. Whitecap Books: North Vancouver, BC.

Steele, M. 1988. The First Hundred Years: An Illustrated Celebration. The Vancouver Board of Parks and Recreation: Vancouver.

Stevens, J.C. (date unknown), Hydrographic data book: Eighth Edition, Leopold and Stevens, Inc, Portland Oregon.

Stewart, J.M. 1997. Beaver Lake Bathymetric survey. J.M. Stewart Surveys Limited. Prepared for Beaver Lake Environmental Enhancement Project. Not Published.

Stull, R., 1995, Meteorology Today For Scientists and Engineers, West Publishing Company, St. Paul, Minneapolis.

Talisman Land Resource Consultants. 1995a. Comparative Environmental Assessment of lions Gate Crossing Options Related to Stanley Park and First Narrows: Soil and Drainage. Prepared for Ministry of Transportation and Highways. Not Published.

Talisman Land Resource Consultants. 1995b. Comparative Environmental Assessment of lions Gate Crossing Options Related to Stanley Park and First Narrows: Vegetation. Prepared for Ministry of Transportation and Highways. Not Published.

Tanner, C.B., and J.T. Ritchie, 1974, Evapotranspiration: Empiricisms and modeling, paper presented at Annual Meeting, American Society of Agronomy, Chicago, Ill. Nov. 1974.

Viswanadham, Y., V.P. Silva Filho and R.G.B. Andre, 1991, The Priestly-Taylor parameter  $\alpha$  for the Amazon Forest, Forest Ecology and Management, Vol. 38: 211-225.

Wetzel. Limnology. 1983. WB Saunders Co. Toronto.

Wu, B., and C., Starzyk., 1999, Civil 306, Assignment #3 Culvert Design/ Evaluation Project for the Beaver Lake weir.- un published - in appendix

Zecharias, Y. and W. Brutsaert, 1988, Recession Characteristics of Groundwater Outflow and Base Flow from Mountainous Watersheds, Water Resources Research, Vol. 24(10), 1651-1658.

## 13. Appendices

### 13.1. Appendix I -Culvert flow design

Prepared by: Ben Wu,,Cindy Starzyk - Civil 306

Assignment #3 Culvert Design/ Evaluation Project April 7, 1999

*The relevant information to the weir is only given below*

The maximum design velocity for the culvert will be limited by the burst speed of the adult Cutthroat. The lower limit of its burst speed is 1.9 m/s.

Beaver Lake is a small shallow water-body. It is fed by Prospect Creek, a southeast flowing creek from the highest elevation in the park. A four-inch pipe from the GVRD city water supply supplements the Creek headwaters with flow. In the summer when precipitation is low, this outflow controls the low flow condition. The pressure upstream of the pipe is 40 psi, which creates a discharge of  $0.184\text{m}^3/\text{s}$  from the pipe into Prospect Creek. See appendix 3 for calculations.

Rainfall also supplies Beaver Lake with water. The watershed feeding Beaver Lake is an 84-hectare area, as seen in Figure 2.

The duration time required for storm data was found to be 30 minutes. This is the average time it takes a drop of rain to travel from the upper end of the catchment to the lake. The mean annual flood flow is estimated to be  $1\text{m}^3/\text{s}$ , and the 1 in 10 year flood is  $2\text{m}^3/\text{s}$ . These values were calculated from a 30 minute intensity rainfall determined from 1984 monthly precipitation and creek discharge data as measured by Hatfield Consultants Limited (Hatfield, 1985) and using an assumed runoff coefficient of 0.3 (typical value in forest cover).

The 30-minute rainfall intensity (as measured by The Vancouver Harbor weather station, Environment Canada) with a 100-year return period is 47.5mm per hour which would yield a flow of  $3.325\text{m}^3/\text{s}$ .

#### **Current Culvert Geometry at Beaver Lake**

A weir dams Beaver Creek and forms Beaver Lake. The weir is comprised of a series of three circular, concrete culverts. One 61 centimeter (inside diameter) pipe (culvert 1) that passes through the center of the weir and a series of two 44 centimeter (inside diameter) pipes (culvert 2 and 3) that is adjacent to the weir. Current culvert gradients are 18%, 6%, and 8.4% for culverts 1, 2 and 3 respectively. There is very little roughness within the pipe and flow is most likely supercritical. See Appendix 1 for the locations of each pipe.

The inlet for culvert 1 is a trapezoidal concrete weir structure. The water flows over the structure, drops 15 cm and then flows into the concrete pipe. It is equipped with a trash screen with a 10 cm bar spacing. See Appendix 2, Photograph 1.

A gate blocks the outlet of Culvert 2, sometimes a second board is in place to block water off at a higher level. The cross section of the culvert outlet is detailed in Figure 5-9. The inlet has no trash rack.

#### **Figure 3. End View of Culvert 2**

At the time of the site visit the outlet of culvert 3 was 15 cm above the level of the pool and a jet of water was shooting out from the pipe. See Photograph 3. This jet was hitting the opposite bank of the culvert and severely eroding and undercutting the stream bank.

The current capability of the culverts is as follows (Appendix 3)

	Culvert 1	Culvert2	Culvert 3
Area	$0.292\text{m}^2$	$0.152\text{m}^2$	$0.152\text{m}^2$
Flow Capability	$0.28\text{m}^3/\text{s}$	$0.61\text{m}^3/\text{s}$	$0.71\text{m}^3/\text{s}$

Fish passage is not possible with the current culvert design. The culverts are much too steep and the flow is supercritical. The velocity and Q calculations do not meet Department of Fisheries and Oceans guidelines. The culvert is reported to overflow onto the trail on average every two years. Gravel derived from the trail is evident in the creek bed.

### **Design Requirements**

Low flow	0.184m <sup>3</sup> /s
High flow: 3 x bankfull area	3.47m <sup>2</sup>
100 year flood return period	3.325m <sup>3</sup> /s
Velocity in culvert at 1.5 bank full	1.9 m/s

The bankfull area of Beaver Creek downstream of the culverts was found to be 1.156m<sup>2</sup>. This measurement was calculated using a water level 20cm higher than the water level at the time of the site visit.

A culvert must be able to pass 3 times the bankfull area of water. This is equivalent to 3.47m<sup>2</sup>. The combined area of culverts 1 and 2 are 0.440m<sup>2</sup> which is far below the required amount. As well, the 100 year flood flow is 3.325m<sup>3</sup>/s

The velocity of the water in the culvert at 1.5 times bankfull conditions should not exceed 1.9m/s and overall should have an average velocity no greater than 1m/s. Water traveling through the culvert at 1.5 times the bankfull flow would have a velocity of 3.94 m/s, failing again to meet criteria. See Appendix 3 for all above calculations.

### **Culvert Loading**

The pressures due to soil loading on the culverts range from near zero (from an 8 cm cover of gravel) to 33.06 kPa at the outlet of culvert 1.

The wheel loading due to a 3000kg pick-up truck at the maximum depth of 1.87 meters would be 102.43 kPa. The overall loading the culvert would experience is then be 135.5 kPa. At the minimum depth of 8cm, the wheel loading on the culvert would be 56,000 kPa. See appendix 4 for calculations.

### **Design Recommendations**

Existing culvert 1 could be left in place but blocked off and used only for overflow protection measures. During construction of the new culvert structure, the water can be passed via this culvert so flow is still maintained. Timing of the construction should be checked to minimized fish disturbance.

Culverts 2 and 3 could be replaced by 2 log culverts and a series of step pools. A culvert 3 meters wide by 1.15 meters deep (area of 3.47m<sup>2</sup>) would pass a 100-year flood event (Appendix 5). Making the bottom into a small arched shape replicating the shape of the natural channel would cause the culvert to satisfy minimum flow requirements.

The current grade of 6% and 8.4% for culverts 2 and 3 could easily be converted to a step and pool structure that will be able to pass fish. Around ten drops of 10 to 15cm each over the 15 meter length would accommodate the flow. A concrete brim at the Beaver Lake inlet end of the structure could be used to keep a good constraint on the level of the lake. No trash rack would be necessary.

The design would be a suitable choice for Stanley Park. The boulder, gravel and log construction will improve the esthetics of the site and keep it a natural landscape. An outlet pool constructed of coarse-grained rocks will prevent erosion, which is a current problem. See Appendix 5 for illustrations of this design recommendation.

### **Conclusions**

The present culvert system installed at Beaver Creek fails to meet present design requirements. As a result, fish are unable to pass and frequent flooding occurs. The culvert design fails the following requirements:

- Does not pass water equal to three times the bankfull area (high flow condition)
- The velocity flowing through the culvert at 1.5 bankfull flow is too great to pass fish.
- The slopes, especially the 8.4% grade is too steep. The flow inside is also laminar.
- The outfall pond into Beaver Creek has too great of a drop.

The area could be easily remedied with the following design:

- Installing a 3m by 1.15m log culvert with natural arched gravel bottom. Steps and pools will easily accommodate fish passage.
- Create a log-enclosed area between culvert 2 and 3 so water is prevented from flooding the surrounding forest. Also install a log protection wall along the opposite bank to the discharges of culvert 1 and 3 to prevent erosion.

### **I. Capability of Culverts**

Broad-Crested Weir:  $Q=2/3(2/3g)^{1/2}bY^{3/2}$

Chezy-Manning equation:  $Q=(c/n)AR^{2/3}S^{1/2}$

Assuming  $c=1.0$ ,  $n=0.014$  (for an unfinished concrete pipe),

R = Hydrologic radius = A/perimeter

Culvert 1:

Flow capability of broad-crested weir at inlet:

$$Y = .32\text{m}, b = 0.9\text{m},$$

$$Q = 0.28\text{m}^3/\text{s}$$

Flow capability of pipe:

$$A = 0.292\text{m}^2, R = 0.152\text{ m}, S = 0.18, Q = 2.52\text{m}^3/\text{s}$$

**Culvert 1 is inlet controlled, maximum flow is 0.28m<sup>3</sup>/s**

Culvert 2:

$$A = 0.152\text{m}^2, R = 0.11\text{m}, S = 0.06, Q = 0.61\text{m}^3/\text{s}$$

Culvert 3:

$$A = 0.152\text{m}^2, R = 0.11\text{m}, S = 0.084, Q = 0.72\text{m}^3/\text{s}$$

**Culverts 2 and 3 are limited by culvert 2, maximum flow is 0.61m<sup>3</sup>/s.**

## II. Minimum Flow

Minimum flow requirements determined from GVRD pipe discharging into Prospect Creek:

Pressure in pipe: 40psi, (257.8 kPa)

According to Bernoulli's Equation:  $(V^2/2g) = (P/\rho g)$

$$V = 22.7\text{ m/s}$$

Radius of pipe: 2 inches (0.0508 m)

Area of pipe: 0.0081m<sup>2</sup>

Flow out of pipe:  $Q = Av = 0.184\text{m}^3/\text{s}$

Low flow design criteria is **0.184m<sup>3</sup>/s**

## II. Maximum Flow

Maximum flow requirements were determined from three times the bankfull calculation:

Graph paper was used to measure the area off of the cross section to get a bank full area of 1.156m<sup>2</sup>  
As well, the rainfall intensity with a 100-year return period is 3.325m<sup>3</sup>/s. This must also be considered.

## IV. Velocity Restrictions:

Velocity in the pipes at 1.5 bank full flow are used as the high flow conditions to satisfy fish passage:

Bankfull area = 1.156 m<sup>2</sup>

$$1.5Q_{bf} = 1.734\text{m}^2$$

Combined area of culverts 1 and 2 :

$$\text{Culvert 1 Area} = \pi (0.305)^2 = 0.288\text{m}^2$$

$$\text{Culvert 2 and 3 Area} = \pi (0.22)^2 = 0.152\text{m}^2$$

$$\text{Combined area} = 0.440\text{m}^2$$

$$\text{Velocity} = Q_{bf}/A = 3.94\text{m/s}$$

\*This calculation did not utilize the Mannings equation simulating an inlet control, since the velocity in the pipe is already exceeding the limit when the calculation is preformed for a full pipe.

## Soil Loading on Existing Culverts

Density of gravel: 1800kg/m<sup>3</sup>

Greatest culvert depth: 1.87m (at the outlet of culvert 1)

Pressure at the deepest culvert point:  $P = \rho gh$

$$P = (1800\text{kg/m}^3)(9.81\text{m/s}^2)(1.87\text{m}) = 33.1\text{ kPa}$$

## Traffic Wheel Load on Existing Culverts

Weight of a pick-up truck: 3000kg

Assume the weight is evenly distributed over the four tires  
weight on one tire = 750kg.

From page 162, Craig, Sixth edition Soil Mechanics, 1997:

$$\sigma_z = QI_p/z^2$$

$$Q = 750\text{ kg} \quad z = 1.87\text{ m} \quad I = 0.478$$

$$\sigma_z = (750)(0.478)/(3.5) = 102.43\text{ kPa}$$

Total pressure on culvert at 1.87 meter depth.

$$P = P_{\text{soil}} + P_{\text{wheel}} = 135.53 \text{ kPa}$$

Wheel loading at the depth of 8cm (the minimum depth):

$$\sigma_z = \frac{QI}{z^2}$$

$$Q = 750 \text{ kg} \quad z = 0.08 \text{ m} \quad I = 0.478$$

$$= (750)(0.478) / (0.0064) = 56,015 \text{ kPa}$$

13.2. Appendix II plan view of weir

Map of Beaver Creek Weir

-if this slope carried back through to the weir the lake would be at a level of 35.8m, 1.4m lower than present.

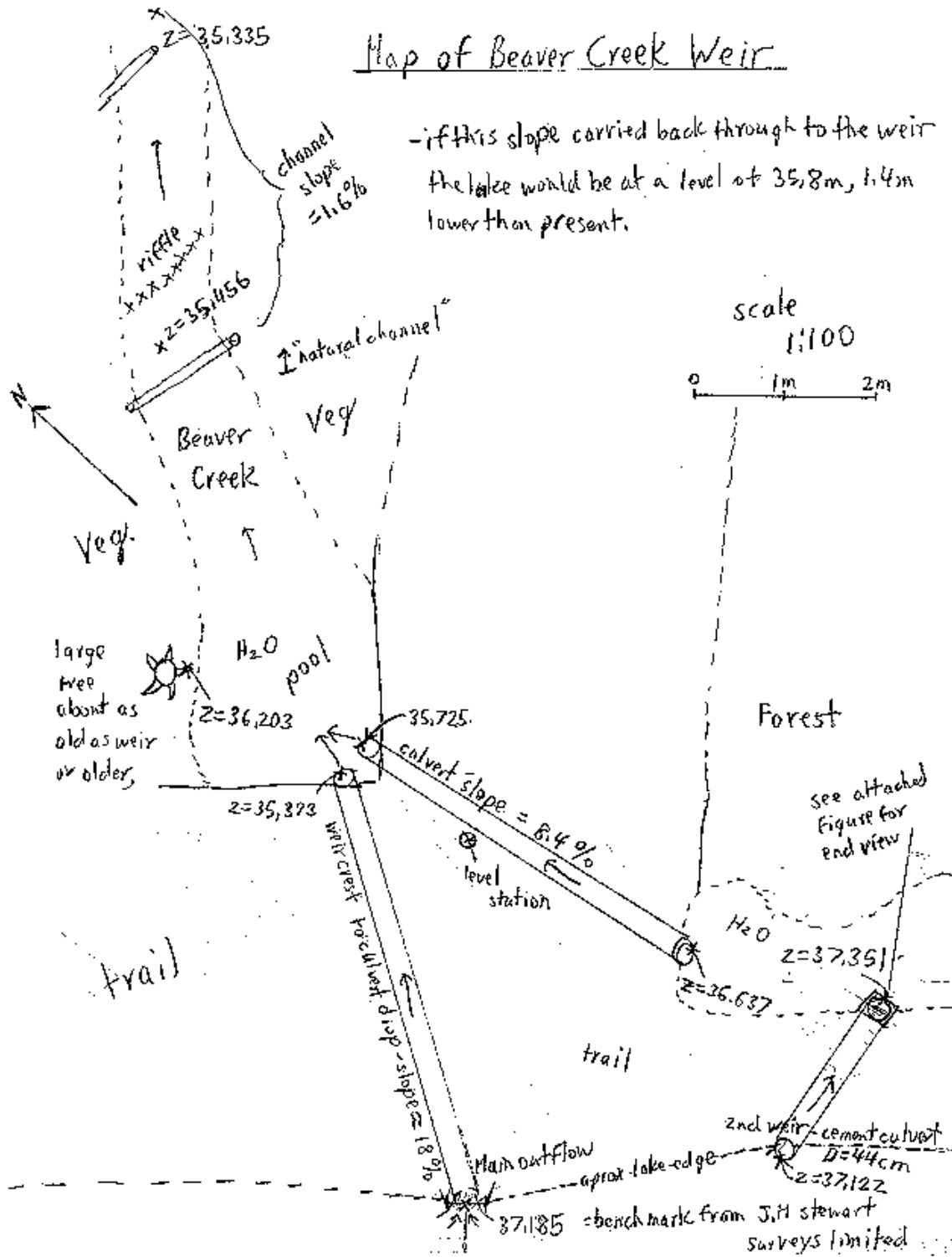

### 13.3. Appendix III inorganic grain size analysis

diameter (micrometers)	AL4	cumulative percent finer	mass in interval (%)	cumulative percent finer	mass in interval (%)	cumulative percent finer	mass in interval (%)	cumulative percent finer	mass in interval (%)	Ah3	cumulative percent finer	mass in interval (%)
		0-156		275-323		323-355		372-475			0-57(1)	
250		100		100		100		100			100	
125.00		99.37	0.63	99.40	0.60	99.05	0.95	98.48	1.52		96.79	3.21
100.00		99.37	0.00	99.40	-0.00	99.05	0.00	98.48	0.00		95.82	0.97
80.00		99.37	0.00	99.40	0.00	99.05	0.00	98.48	0.00		94.66	1.16
60.00		98.67	0.70	99.10	0.30	99.05	0.00	98.48	0.00		90.79	3.87
50.00		98.57	0.10	98.51	0.60	99.05	0.00	98.48	0.00		86.72	4.07
40.00		98.08	0.50	97.41	1.09	98.16	0.89	98.48	0.00		80.14	6.58
30.00		96.79	1.29	96.72	0.70	97.47	0.69	98.48	0.00		69.98	10.16
25.00		95.89	0.89	96.12	0.60	96.57	0.89	97.49	0.98		63.01	6.97
20.00		93.71	2.19	93.64	2.49	95.19	1.39	97.20	0.30		54.59	8.42
15.00		85.46	8.25	84.79	8.85	91.42	3.76	97.00	0.20		44.91	9.68
10.00		45.71	39.75	50.79	34.00	76.27	15.15	94.93	2.07		33.29	11.61
8.00		21.26	24.44	33.10	17.69	64.98	11.29	93.36	1.58		28.46	4.84
6.00		13.51	7.75	25.05	8.05	52.30	12.68	89.62	3.74		22.65	5.81
5.00		11.82	1.69	22.46	2.58	45.17	7.13	87.84	1.77		19.26	3.39
4.00		10.14	1.69	19.98	2.49	37.24	7.92	70.41	17.43		15.68	3.58
3.00		8.55	1.59	17.00	2.98	28.63	8.62	16.84	53.57		12.49	3.19
2.00		6.76	1.79	12.33	4.67	19.71	8.91	4.23	12.61		9.49	3.00
1.50		5.27	1.49	8.95	3.38	14.36	5.35	4.23	0.00		7.36	2.13
1.00		2.98	2.29	3.98	4.97	7.53	6.83	3.84	0.39		4.94	2.42
median grain size		10.29		9.10		5.47		3.56			16.74	

diameter (micrometers)	BL1	cumulative percent finer	mass in interval (%)	cumulative percent finer	mass in interval (%)	cumulative percent finer	mass in interval (%)	cumulative percent finer	mass in interval (%)	cumulative percent finer	mass in interval (%)	cumulative percent finer	mass in interval (%)	cumulative percent finer
		0-57		57-115		115-154		154-235		305-388		433-473		473-686
250		100		100		100		100		100		100		100
125.00		99.67	0.33	99.40	0.60	99.40	0.60	98.08	1.92	98.52	1.48	95.91	4.09	98.51
100.00		97.97	1.69	99.40	0.00	99.40	0.00	98.08	0.00	98.52	0.00	95.91	-0.00	98.51
80.00		96.68	1.30	98.50	0.89	98.70	0.70	97.98	0.10	98.52	0.00	95.14	0.77	98.51
60.00		92.69	3.99	96.12	2.39	96.22	2.48	97.49	0.49	98.52	0.00	93.71	1.44	98.51
50.00		88.11	4.58	93.04	3.08	93.14	3.08	97.00	0.49	98.52	0.00	92.94	0.77	98.51
40.00		80.23	7.87	86.28	6.76	86.38	6.76	96.41	0.59	98.23	0.30	91.88	1.06	96.64
30.00		68.37	11.86	74.85	11.43	74.95	11.43	95.72	0.69	96.95	1.28	89.10	2.78	94.28
25.00		60.90	7.48	68.68	6.16	68.78	6.16	94.74	0.98	96.16	0.79	86.90	2.21	92.51
20.00		52.13	8.77	61.53	7.16	61.53	7.26	93.76	0.98	95.76	0.39	84.31	2.59	88.86
15.00		40.46	11.66	48.11	13.42	48.21	13.32	91.70	2.06	94.78	0.99	78.36	5.95	65.81
10.00		27.61	12.86	23.46	24.65	23.46	24.75	86.01	5.69	80.99	13.79	55.15	23.21	11.23
8.00		23.12	4.49	17.30	6.16	17.30	6.16	82.48	3.53	44.63	36.35	30.69	24.46	8.08
6.00		17.64	5.48	14.21	3.08	14.21	3.08	75.32	7.16	6.60	38.03	14.96	15.73	7.68
5.00		14.75	2.89	12.92	1.29	12.92	1.29	61.10	14.22	3.65	2.96	12.28	2.69	7.39
4.00		12.06	2.69	11.73	1.19	11.73	1.19	24.72	36.39	3.35	0.30	10.17	2.11	7.09
3.00		9.67	2.39	9.74	1.99	9.74	1.99	2.75	21.97	3.25	0.10	8.54	1.63	7.09
2.00		6.48	3.19	7.06	2.68	7.06	2.68	2.06	0.69	3.25	0.00	6.62	1.92	7.39
1.50		4.39	2.09	5.47	1.59	5.37	1.69	1.77	0.29	3.05	0.20	5.08	1.53	7.39
1.00		2.19	2.19	2.78	2.68	2.68	2.68	1.57	0.20	2.27	0.79	1.92	3.17	7.19
median grain size		18.92		17.61		15.39		4.59		8.17		9.35		13.62

13.4. ***Appendix IV - metals and organic***

**Appendix V - recession data**

volume (liters)	mean run time (sec)	time 0= 12pm Dec. 17th (hrs)	discharge (L/s)	Q/Qo	without 1st sample ln(Q/Qo)		k(total)= (Hr <sup>-1</sup> )
9.575	3.460	9.330	2.767	1.000	-0.000	not used to calculate k	0.0194
9.575	5.685	23.083	1.684	0.609	0.497		k( less 1st=
9.575	6.500	33.000	1.473	0.532	0.631		0.0177
9.575	8.151	44.167	1.175	0.424	0.857		r( total) =
9.575	9.400	55.330	1.019	0.368	0.999		0.9912
9.575	15.996	80.500	0.599	0.216	1.531		r(less 1st)=
9.575	18.143	91.000	0.528	0.191	1.657		0.9978

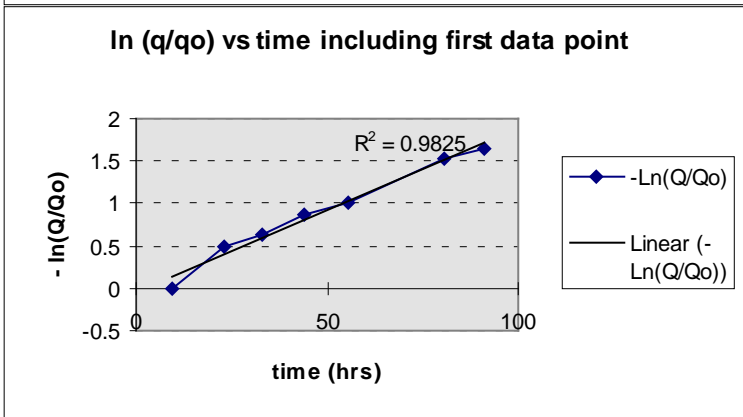
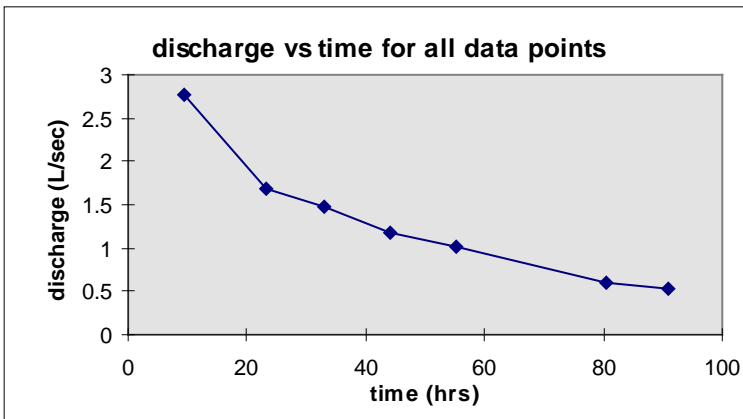

**13.5. Appendix VI metals, not normalized by carbon**

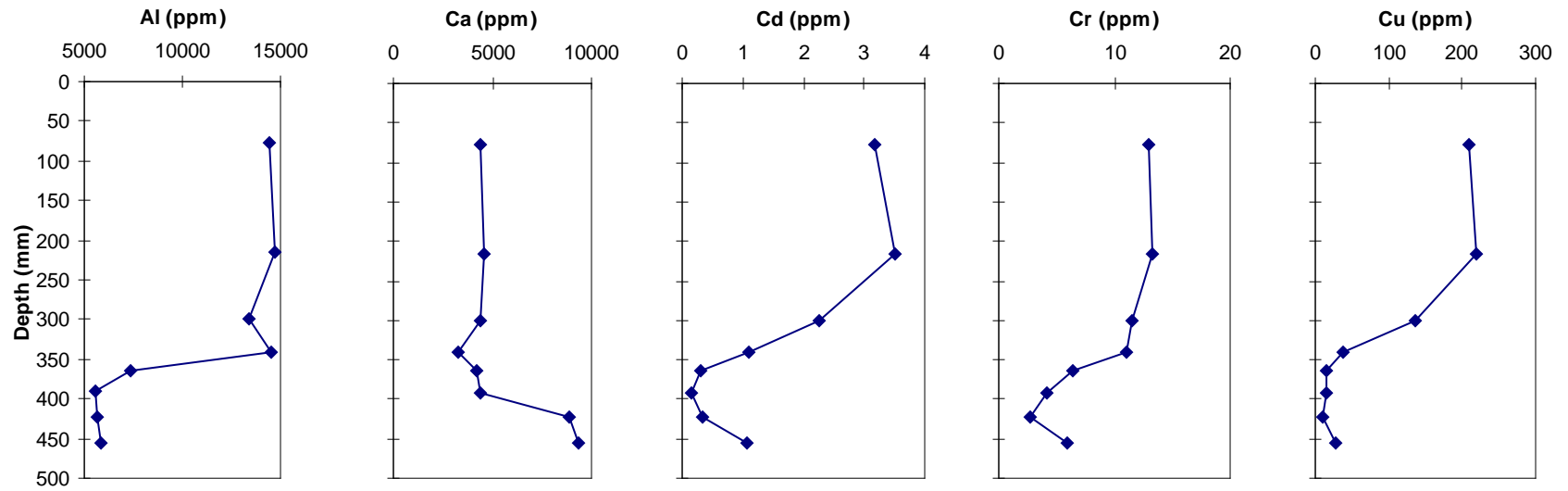

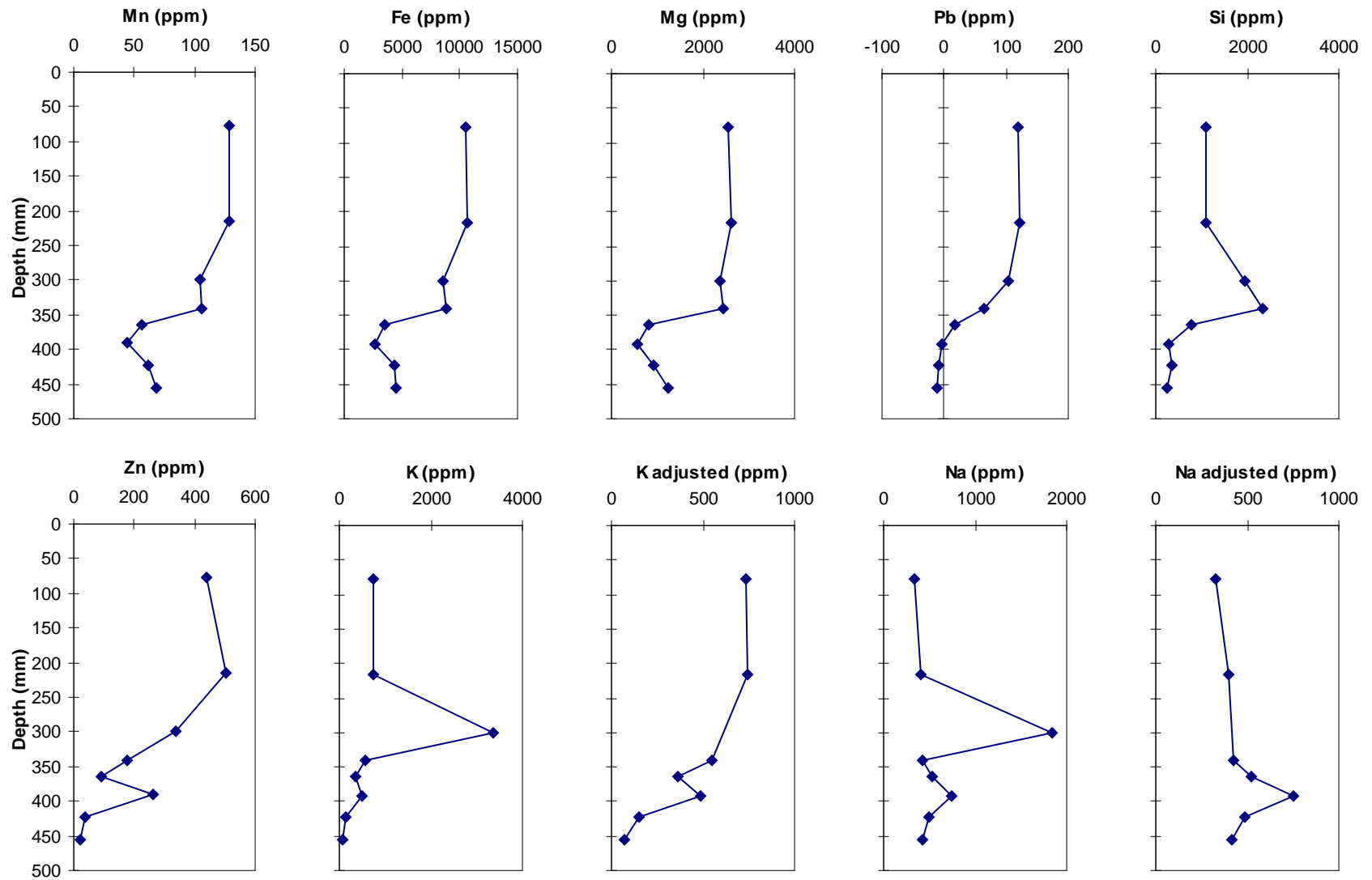

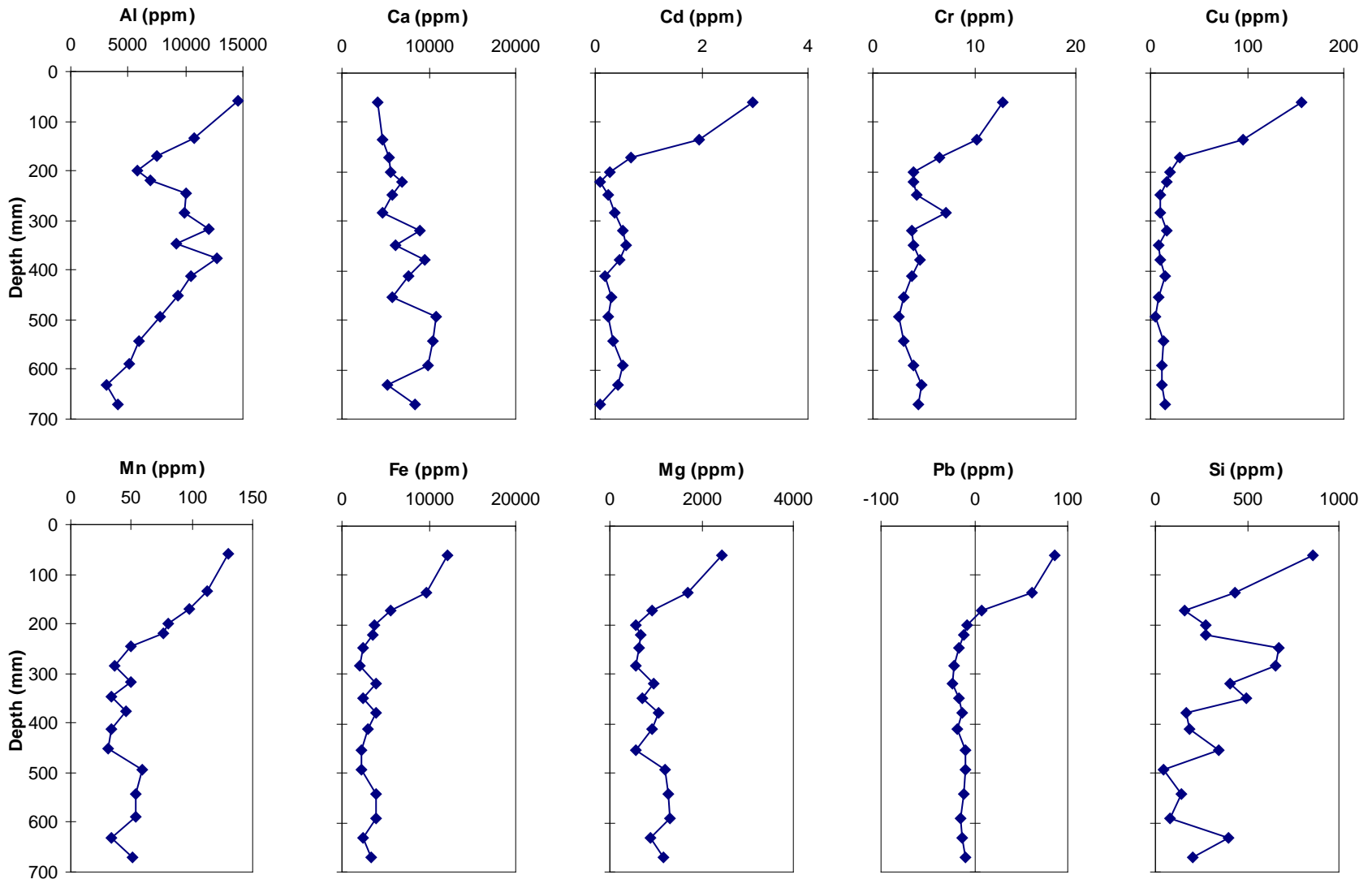

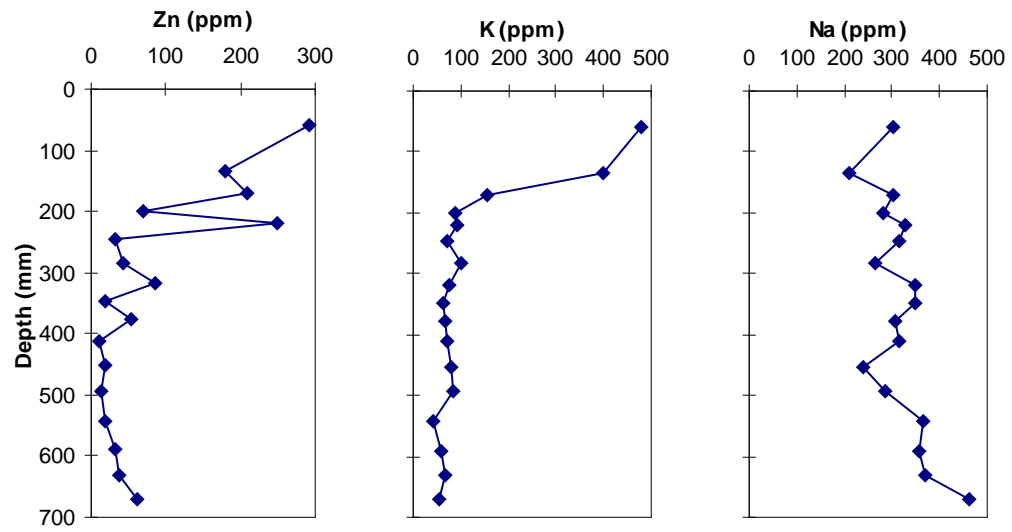

**13.6. *Appendix VII -Moist and ground up core descriptions***